

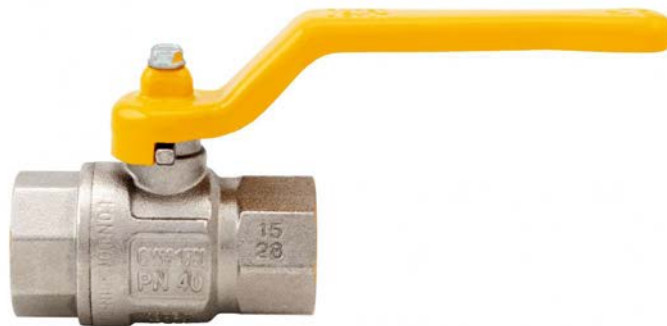

ТЕХНИЧЕСКИЙ КАТАЛОГ

# ПОЛНОПРОХОДНОЙ ШАРОВЫЕ КРАНЫ ДЛЯ ГАЗА: LONDON



## > ПРЕДПРИЯТИЕ

Компания ITAP SpA была основана в г. Лумеццане (Брешиа) в 1972 году и в настоящее время является лидирующим производителем кранов, фитингов и распределительных коллекторов для систем водоснабжения и отопления.

Благодаря полностью автоматизированному производству, располагающему 85 автоматизированных станков и 55 сборочными линиями, Компания может выпускать по 400.000 изделий в день.

Стремление к новшествам и соблюдение технических нормативов подтверждено сертификатом ISO 9001. Ориентация на качество всегда считалась решающим фактором для достижения значительных коммерческих результатов: сегодня ITAP с гордостью предлагает товары, сертифицированные многочисленными организациями во всем мире.

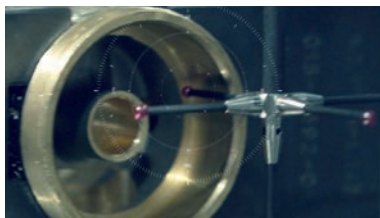
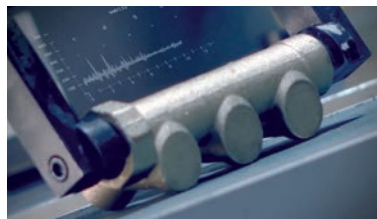
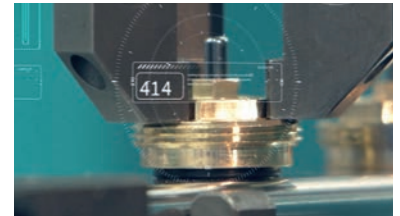
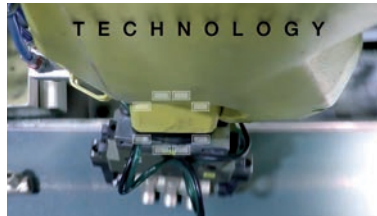

> Изделия ITAP получили сертификацию более чем 30 сертификационных организаций во всем мире.





# ПОЛНОПРОХОДНОЙ ШАРОВЫЕ КРАНЫ ДЛЯ ГАЗА: LONDON

## 066 LONDON кран шаровый, полнопроходной

LONDON

ОДОБРЕНО СОГЛАСНО СТАНДАРТА EN 331 (до 2").



РАЗМЕР	ДАВЛЕНИЕ	КОД ИТАР	УПАКОВКА
1/4" (DN 8)	5bar/72.5psi	066B014	12/192
3/8" (DN 10)	5bar/72.5psi	066B038	12/192
1/2" (DN 15)	5bar/72.5psi	066B012	10/100
3/4" (DN 20)	5bar/72.5psi	066B034	8/64
1" (DN 25)	5bar/72.5psi	066B100	6/48
1"1/4 (DN 32)	5bar/72.5psi	066B114	4/32
1"1/2 (DN 40)	5bar/72.5psi	066B112	2/16
2" (DN 50)	5bar/72.5psi	066B200	2/14
2"1/2 (DN 65)	18bar/261psi	1200212G	1/5
3" (DN 80)	16bar/232psi	1200300G	1/3
4" (DN 100)	14bar/203psi	1200400G	1/2

### КАЧЕСТВО



### ОПИСАНИЕ

Резьбы: ВР-ВР или НР-ВР.

Корпус никелированная латунь.

Стальная ручка-рычаг (Алюминиевая ручка-рычаг 2"1/2 - 3" - 4") или Алюминиевая ручка-бабочка или плоский рычаг.

Минимальная и максимальная рабочие температуры: -20°C, 60°C.

ВР:

- ISO 7/1 Rp (эквивалентно DIN EN 10226-1 и BS EN 10226-1) от 1/4" до 2".

- ISO 228 (эквивалентно DIN EN ISO 228 и BS EN ISO 228) 2"1/2 - 3" - 4"

НР:

- ISO 7/1 R (эквивалентно DIN EN 10226-1 и BS EN 10226-1) от 1/4" до 2".

- ISO228 (equivalent to DIN EN ISO 228 and BS EN ISO 228) sizes 2"1/2, 3" and 4"



# ПОЛНОПРОХОДНОЙ ШАРОВЫЕ КРАНЫ ДЛЯ ГАЗА: LONDON

## OVERALL DIMENSIONS

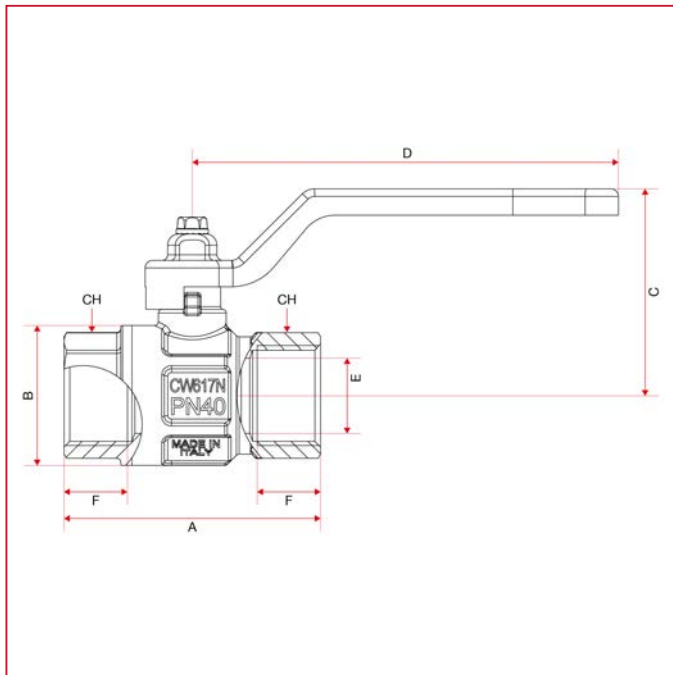

	1/4"	3/8"	1/2"	3/4"	1"	1"1/4	1"1/2	2"	2"1/2	3"	4"
DN	8	10	15	20	25	32	40	50	65	80	100
A	49,5	52,4	61	68	85	99,5	109	130	148	168	204
B	23,5	24	30,5	37	45,5	58	71	85	122	142	180
C	37,3	37,3	48,8	54,8	56,8	75	90,3	97,3	126,75	135,75	153,75
D	80	80	88,5	113	113	138	157,8	157,8	250	250	250
E	10	10	15	20	25	32	40	50	65	80	100
F	11	11,4	15	16,3	19,1	21,4	21,4	25,7	25	27,5	30
CH	18	21	25	31	38	47	54	66			
Kg/cm <sup>2</sup> bar	5	5	5	5	5	5	5	5	18	16	14
LBS - psi	72,5	72,5	72,5	72,5	72,5	72,5	72,5	72,5	261	232	203



# ПОЛНОПРОХОДНОЙ ШАРОВЫЕ КРАНЫ ДЛЯ ГАЗА: LONDON

**MATERIALS sizes 1/4" through 3/8"**

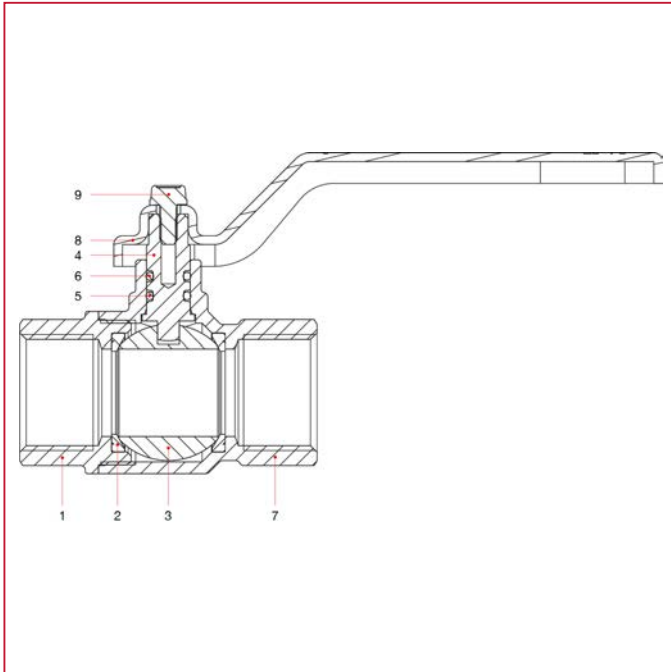

N.	ОПИСАНИЕ	КО Л.	МАТЕРИАЛ
1	Female end adapter	1	Nickel-plated brass CW617N
2	Seat	2	P.T.F.E.
3	Ball	1	Chrome-plated brass CW614N
4	Stem	1	Brass CW614N
5	O-ring	1	NBR
6	O-ring	1	Viton®
7	Body	1	Nickel-plated brass CW617N
8	Lever	1	Varnished steel P04
9	Screw	1	Zinc-plated steel C4C



# ПОЛНОПРОХОДНОЙ ШАРОВЫЕ КРАНЫ ДЛЯ ГАЗА: LONDON

MATERIALS sizes 1/2" through 2"

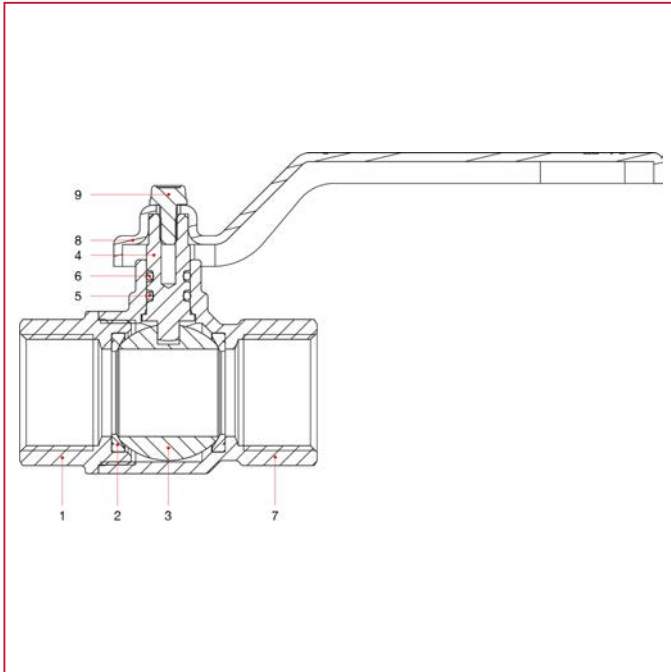

N.	ОПИСАНИЕ	КО Л.	МАТЕРИАЛ
1	Female end adapter	1	Nickel-plated brass CW617N
2	Seat	2	P.T.F.E.
3	Ball	1	Chrome-plated brass CW617N
4	Stem	1	Brass CW614N
5	O-ring	1	NBR
6	O-ring	1	Viton®
7	Body	1	Nickel-plated brass CW617N
8	Lever	1	Varnished steel P04
9	Screw	1	Zinc-plated steel C4C



# ПОЛНОПРОХОДНОЙ ШАРОВЫЕ КРАНЫ ДЛЯ ГАЗА: LONDON

**MATERIALS sizes 2"1/2 through 4"**

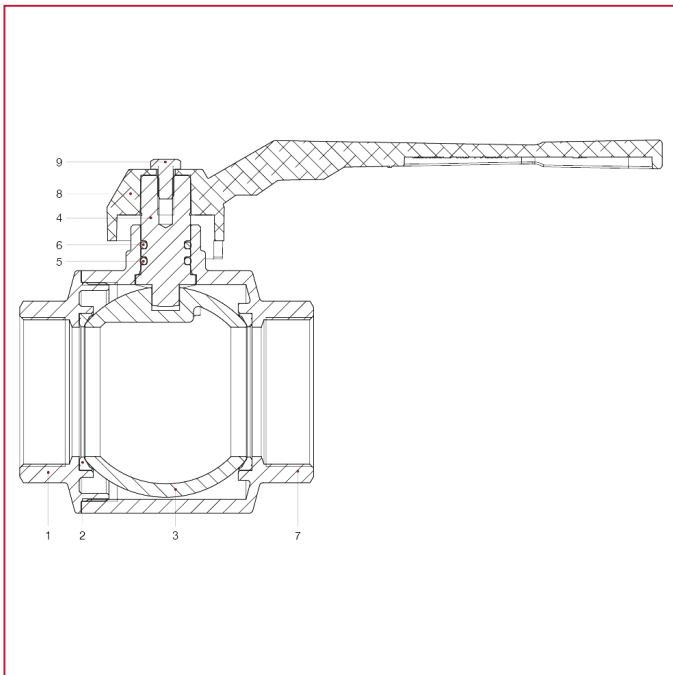

N.	ОПИСАНИЕ	КО Л.	МАТЕРИАЛ
1	Female end adapter	1	Nickel-plated brass CW617N
2	Seat	2	P.T.F.E.
3	Ball	1	Chrome-plated brass CW617N
4	Stem	1	Brass CW614N
5	O-ring	1	NBR
6	O-ring	1	Viton®
7	Body	1	Nickel-plated brass CW617N
8	Lever	1	Aluminium
9	Screw	1	Zinc-plated CB4 FF (C34)



# ПОЛНОПРОХОДНОЙ ШАРОВЫЕ КРАНЫ ДЛЯ ГАЗА: LONDON

## INSTALLATION

The itap S.p.A.'s valves are bi-directional, that means they manage the flow in both the directions.

The valves are composed by a ball, two seal in PTFE material, one stem, two sailing rings (O-Rings), one handle and a couple of parts made of brass (body and end adapter) that contain them and that are assembled by means of thread and a sealed material to obtain their aim.

In order to avoid that the sealed material gets broken and then the valve loses the connection between the body and the end adapter, it's necessary to avoid to submit the two parts under the influence of a torque.

For the installation normal hydraulic practices must be used, and especially:

- ones have to be sure that the two pipes are correctly aligned;
- during the assembling process the installer has to apply its assembling tools at the end that is nearest to the pipe;
- the application of the sealing materials by the fitter (PTFE or hempen cloth) must be limited at the thread zone. An excess should interfere in the ball-gasket's closure zone, compromising the tightness.
- in the case that the fluid transported presents some impurities (dust, water too hard, etc.) ones have to remove these impurities by the means of a filter. Otherwise they could damage the seals.

## DISASSEMBLY

To remove the valve from the pipe line or anyhow before to unscrew the junctions linked to it:

- wear the clothing protective normally required to work with the fluid transported within the line;
- depressurize the line and operate in this way:
  - positioning the valve in opened position and then empty the line;
  - handle the valve to put down the residue pressure contained inside the space between the ball and the body before of remove it from the line;
- during the disassembly apply the screw tool at the end of the valve nearest the pipe;

## MAINTENANCE

Verify the valve periodically, according to its application's field and its works' field and its work's conditions, in order to be sure that the valve works correctly.

## WARNINGS

- any deterioration or destruction of any part of the manually operated ball valve shall result in the need to replace complete valve: alterations to any part of the complete valve shall result in the valve no longer being in compliance with the performance requirements of EN 331 standard;
- ensure that the manually operated ball valve allows an adequate flow rate for its intended use;
- all installations should be performed in accordance with existing local installation regulations and codes of practice where they exist;
- it is imperative to follow the installation instructions of the manually operated ball valve manufacturer and of the appliance manufacturer, including those for the correct position of the connection point for the valve.

## MANUFACTURER

ITAP S.p.A.

via Ruca 19/21 - 25065

Lumezzane (BS), Italy

Телефон: +39 030 8927011

Факс: +39 030 8921990

email: [info@itap.it](mailto:info@itap.it)

web: [www.itap.it](http://www.itap.it)





# ПОЛНОПРОХОДНОЙ ШАРОВЫЕ КРАНЫ ДЛЯ ГАЗА: LONDON

## LOSS DIAGRAM (With water), size 1/4" through 2"

	1/4"	3/8"	1/2"	3/4"	1"	1"1/4"	1"1/2"	2"	2"1/2"	3"	4"
<b>KV</b>	3,45	5,00	15,65	26,26	41,44	63,69	101	169	376	472	892

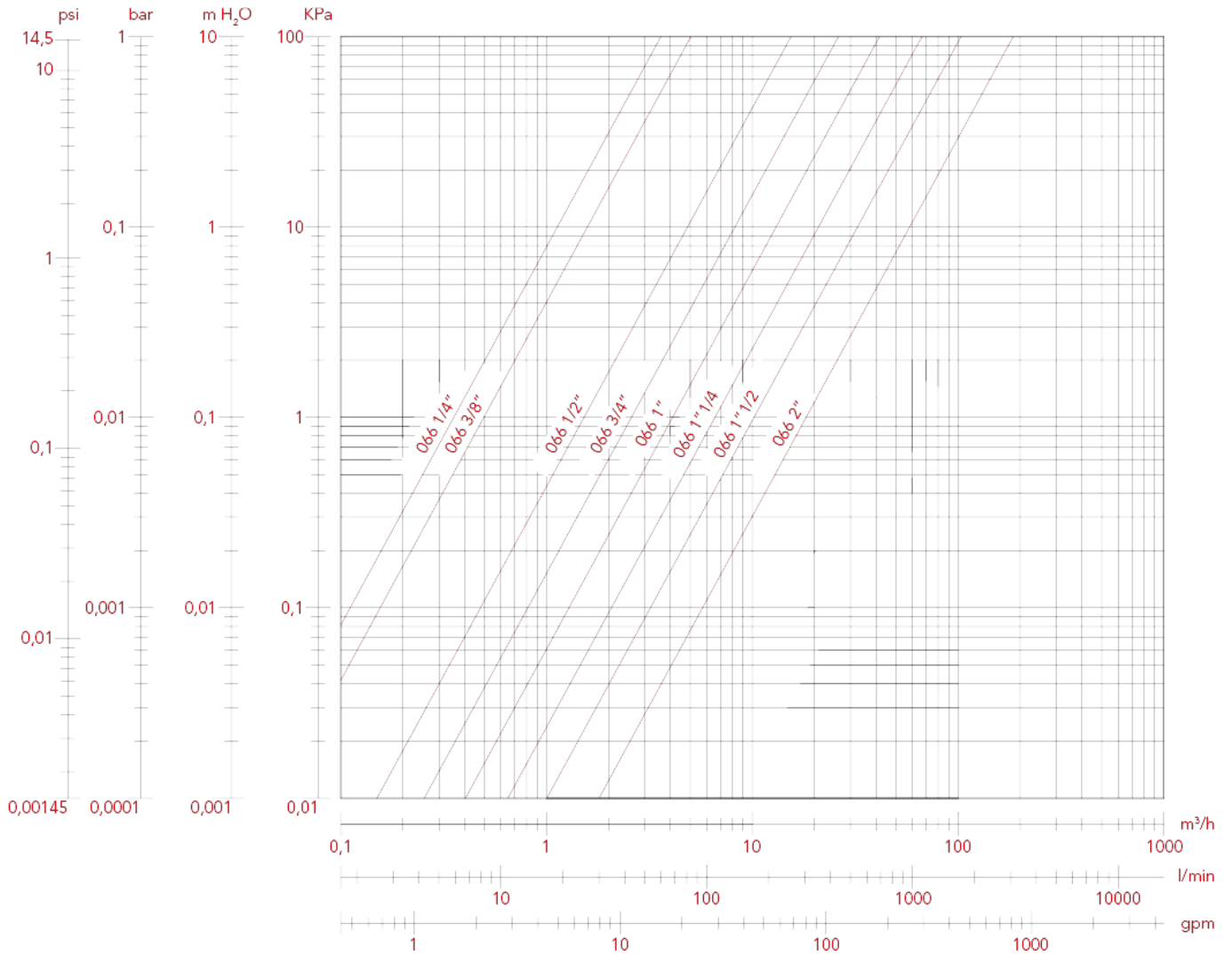



# ПОЛНОПРОХОДНОЙ ШАРОВЫЕ КРАНЫ ДЛЯ ГАЗА: LONDON

## LOSS DIAGRAM (With water), size 2"1/2 through 4"

	1/4"	3/8"	1/2"	3/4"	1"	1"1/4"	1"1/2"	2"	2"1/2"	3"	4"
<b>KV</b>	3,45	5,00	15,65	26,26	41,44	63,69	101	169	376	472	892

	3,45	5,00	15,65	26,26	41,44	63,69	101	169	376	472	892
<b>KV</b>	3,45	5,00	15,65	26,26	41,44	63,69	101	169	376	472	892

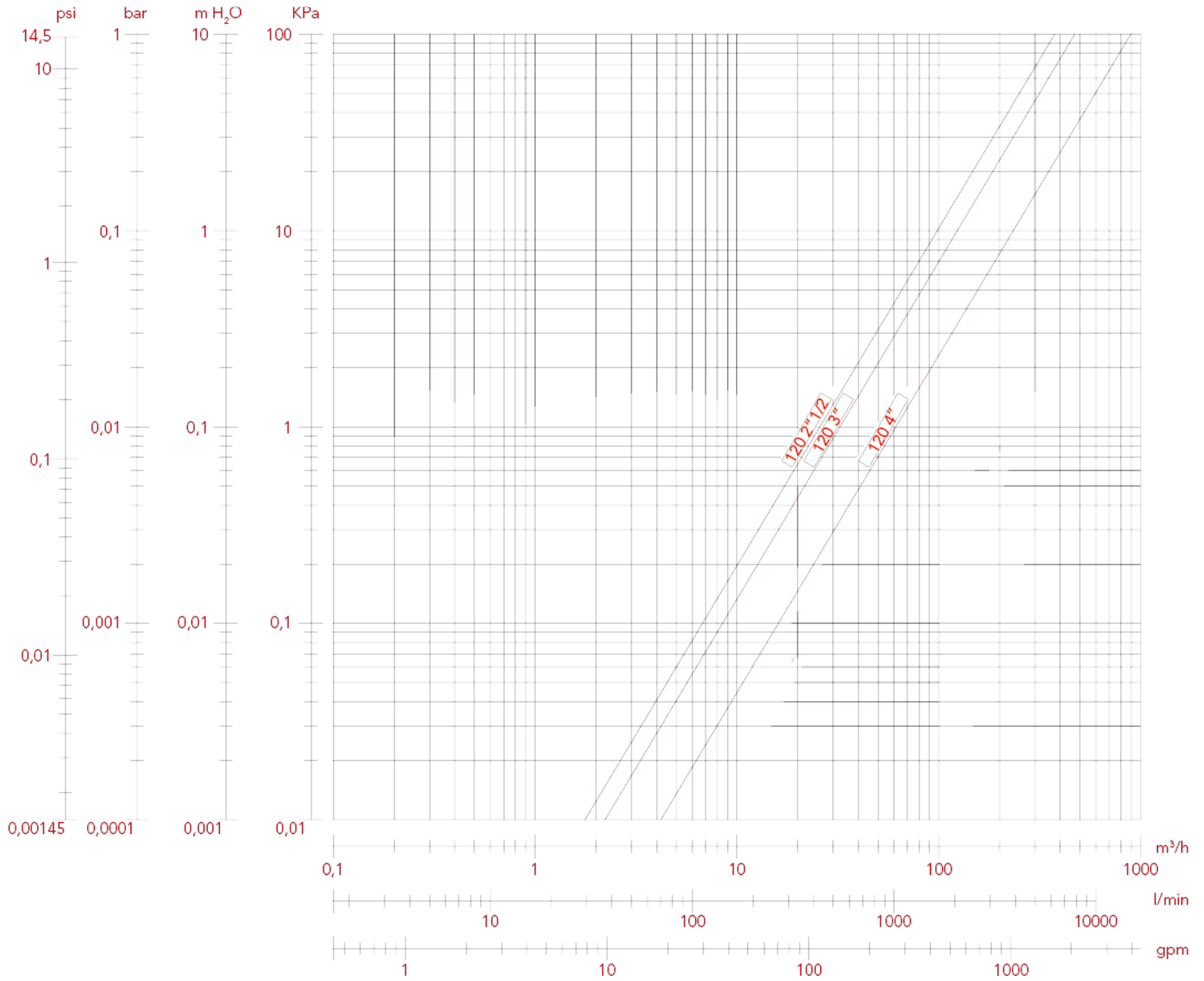



# ПОЛНОПРОХОДНОЙ ШАРОВЫЕ КРАНЫ ДЛЯ ГАЗА: LONDON

## PRESSURE-TEMPERATURE DIAGRAM

The values shown by the dropping lines state the maximum limit of employment of the valves.  
The shown values are approximate.

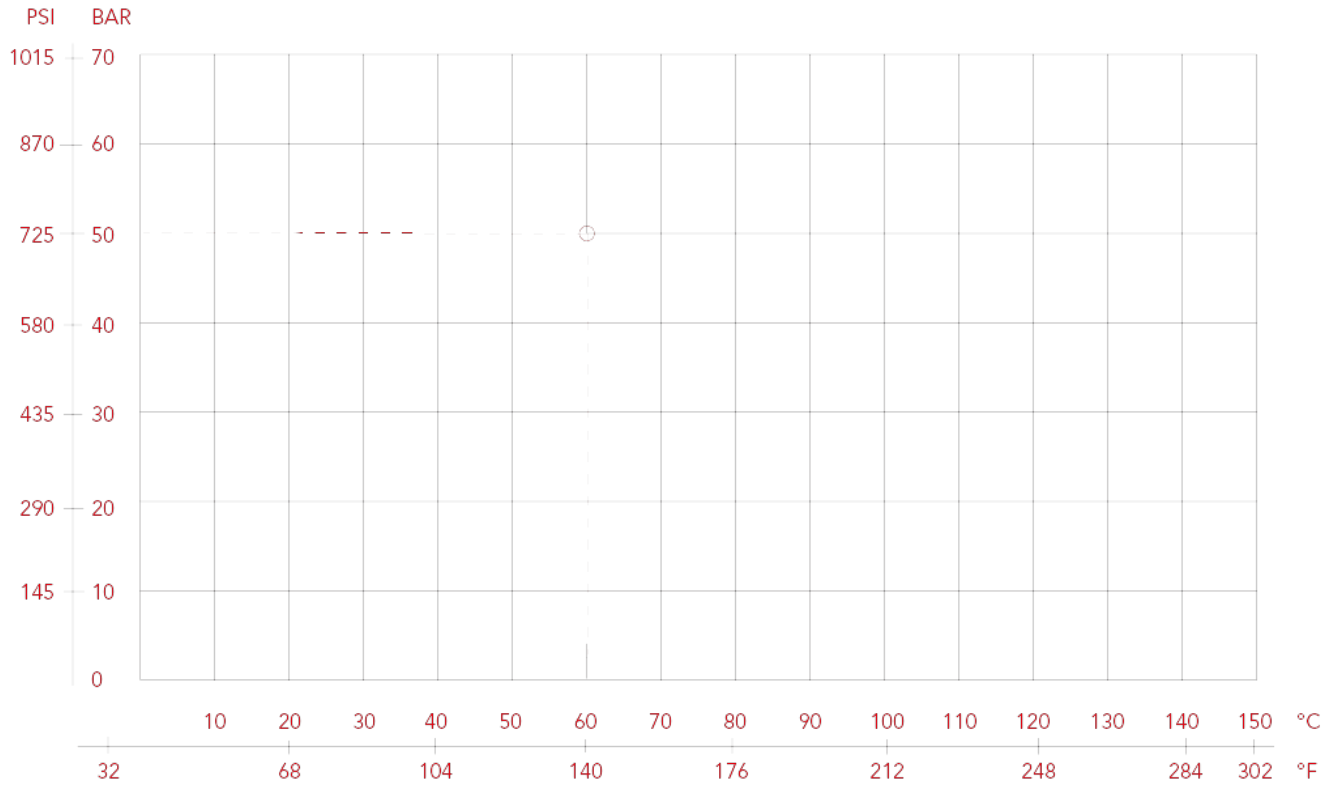



# ПОЛНОПРОХОДНОЙ ШАРОВЫЕ КРАНЫ ДЛЯ ГАЗА: LONDON

## 067 LONDON кран шаровый, полнопроходной

LONDON

ОДОБРЕНО СОГЛАСНО СТАНДАРТА EN 331 (до 2").



РАЗМЕР	ДАВЛЕНИЕ	КОД ИТАР	УПАКОВКА
1/4" (DN 8)	5bar/72.5psi	067B014	12/192
3/8" (DN 10)	5bar/72.5psi	067B038	12/132
1/2" (DN 15)	5bar/72.5psi	067B012	10/100
3/4" (DN 20)	5bar/72.5psi	067B034	8/64
1" (DN 25)	5bar/72.5psi	067B100	6/48
1"1/4 (DN 32)	5bar/72.5psi	067B114	4/24
1"1/2 (DN 40)	5bar/72.5psi	067B112	2/16
2" (DN 50)	5bar/72.5psi	067B200	2/14
3" (DN 80)	16bar/232psi	1210300G	1/3
2"1/2 (DN 65)	18bar/261psi	1210212G	1/5
4" (DN 100)	14bar/203psi	1210400G	1/2

### КАЧЕСТВО



### ОПИСАНИЕ

Резьбы: ВР-ВР или НР-ВР.

Корпус никелированная латунь.

Стальная ручка-рычаг (Алюминиевая ручка-рычаг 2"1/2 - 3" - 4") или Алюминиевая ручка-бабочка или плоский рычаг.

Минимальная и максимальная рабочие температуры: -20°C, 60°C.

ВР:

- ISO 7/1 Rp (эквивалентно DIN EN 10226-1 и BS EN 10226-1) от 1/4" до 2".

- ISO 228 (эквивалентно DIN EN ISO 228 и BS EN ISO 228) 2"1/2 - 3" - 4"

НР:

- ISO 7/1 R (эквивалентно DIN EN 10226-1 и BS EN 10226-1) от 1/4" до 2".

- ISO228 (equivalent to DIN EN ISO 228 and BS EN ISO 228) sizes 2"1/2, 3" and 4"



# ПОЛНОПРОХОДНОЙ ШАРОВЫЕ КРАНЫ ДЛЯ ГАЗА: LONDON

## OVERALL DIMENSIONS

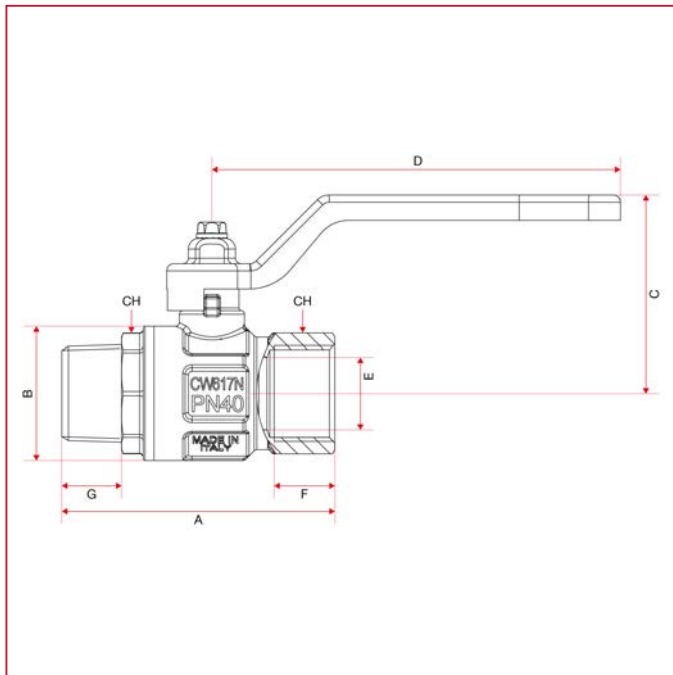

	1/4"	3/8"	1/2"	3/4"	1"	1"1/4	1"1/2	2"	3"	2"1/2	4"
DN	8	10	15	20	25	32	40	50	80	65	100
A	56,9	58,9	68	75,5	90,5	105	115,5	135,5	178	155,5	208
B	23,5	24	30,5	37	45,5	58	71	85	142	122	180
C	37,3	37,3	48,8	54,8	58,8	75	90,3	97	135,75	126,75	153,75
D	80	80	88,5	113	113	138	157,8	157,8	250	250	250
E	8	10	15	20	25	32	39	50	74	63	97
F	11	11,4	15	16,3	19,1	21,4	21,4	25,7	27,5	25	30
G	11	11,5	15	16,5	19	21,5	21,5	26	24	21	23
CH	18	21	25	31	38	47	54	66			
Kg/cm <sup>2</sup> bar	5	5	5	5	5	5	5	5	16	18	14
LBS - psi	72,5	72,5	72,5	72,5	72,5	72,5	72,5	72,5	232	261	203



# ПОЛНОПРОХОДНОЙ ШАРОВЫЕ КРАНЫ ДЛЯ ГАЗА: LONDON

**MATERIALS sizes 1/4" through 3/8"**

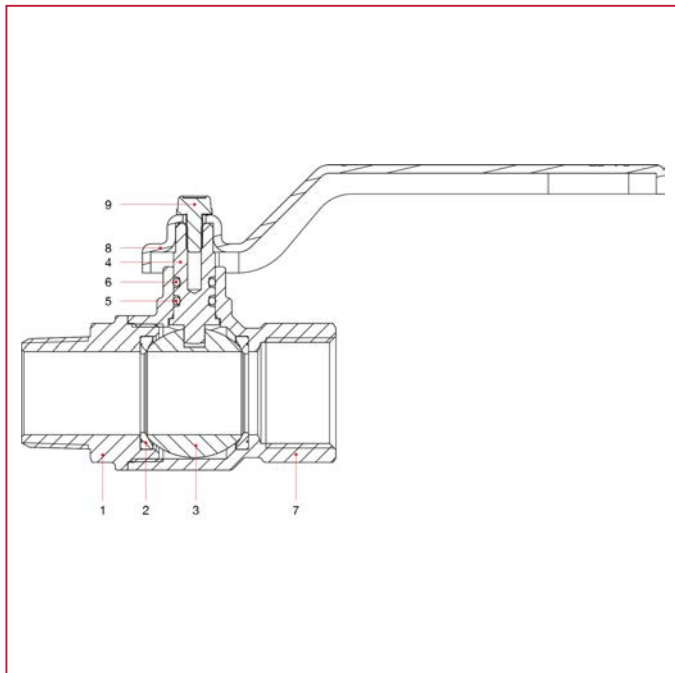

N.	ОПИСАНИЕ	КО Л.	МАТЕРИАЛ
1	Male end adapter	1	Nickel-plated brass CW617N
2	Seat	2	P.T.F.E.
3	Ball	1	Chrome-plated brass CW614N
4	Stem	1	Brass CW614N
5	O-ring	1	NBR
6	O-ring	1	Viton®
7	Body	1	Nickel-plated brass CW617N
8	Lever	1	Varnished steel P04
9	Screw	1	Zinc-plated steel C4C



# ПОЛНОПРОХОДНОЙ ШАРОВЫЕ КРАНЫ ДЛЯ ГАЗА: LONDON

MATERIALS sizes 1/2" through 2"

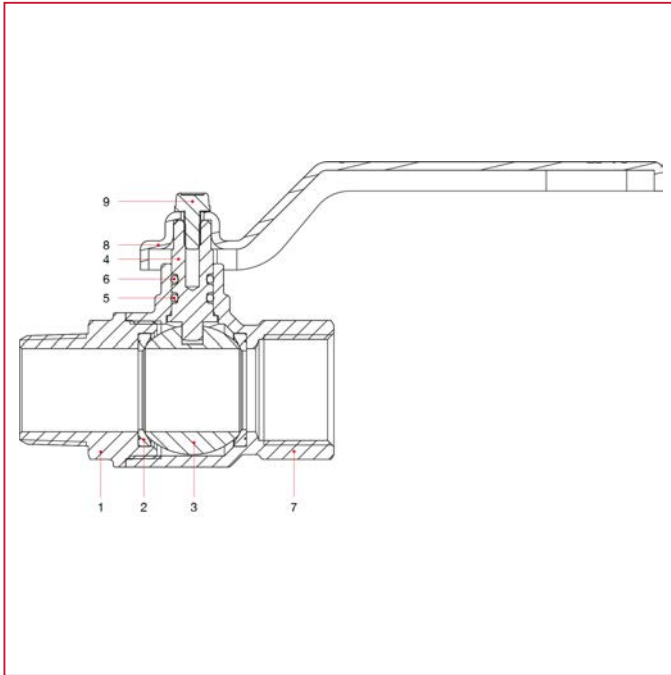

N.	ОПИСАНИЕ	КО Л.	МАТЕРИАЛ
1	Male end adapter	1	Nickel-plated brass CW617N
2	Seat	2	P.T.F.E.
3	Ball	1	Chrome-plated brass CW617N
4	Stem	1	Brass CW614N
5	O-ring	1	NBR
6	O-ring	1	Viton®
7	Body	1	Nickel-plated brass CW617N
8	Lever	1	Varnished steel P04
9	Screw	1	Zinc-plated steel C4C



# ПОЛНОПРОХОДНОЙ ШАРОВЫЕ КРАНЫ ДЛЯ ГАЗА: LONDON

MATERIALS sizes 2"1/2 through 4"

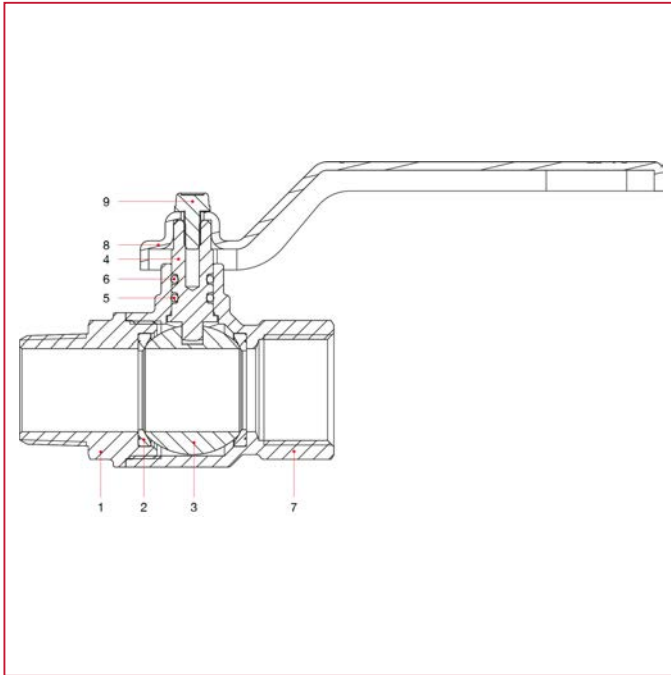

N.	ОПИСАНИЕ	КО Л.	МАТЕРИАЛ
1	Male end adapter	1	Nickel-plated brass CW617N
2	Seat	2	P.T.F.E.
3	Ball	1	Chrome-plated brass CW617N
4	Stem	1	Brass CW614N
5	O-ring	1	NBR
6	O-ring	1	Viton®
7	Body	1	Nickel-plated brass CW617N
8	Lever	1	Aluminium
9	Screw	1	Zinc-plated CB4 FF (C34)





# ПОЛНОПРОХОДНОЙ ШАРОВЫЕ КРАНЫ ДЛЯ ГАЗА: LONDON

## INSTALLATION

The itap S.p.A.'s valves are bi-directional, that means they manage the flow in both the directions.

The valves are composed by a ball, two seal in PTFE material, one stem, two sailing rings (O-Rings), one handle and a couple of parts made of brass (body and end adapter) that contain them and that are assembled by means of thread and a sealed material to obtain their aim.

In order to avoid that the sealed material gets broken and then the valve loses the connection between the body and the end adapter, it's necessary to avoid to submit the two parts under the influence of a torque.

For the installation normal hydraulic practices must be used, and especially:

- ones have to be sure that the two pipes are correctly aligned;
- during the assembling process the installer has to apply its assembling tools at the end that is nearest to the pipe;
- the application of the sealing materials by the fitter (PTFE or hempen cloth) must be limited at the thread zone. An excess should interfere in the ball-gasket's closure zone, compromising the tightness.
- in the case that the fluid transported presents some impurities (dust, water too hard, etc.) ones have to remove these impurities by the means of a filter. Otherwise they could damage the seals.

## DISASSEMBLY

To remove the valve from the pipe line or anyhow before to unscrew the junctions linked to it:

- wear the clothing protective normally required to work with the fluid transported within the line;
- depressurize the line and operate in this way:
  - positioning the valve in opened position and then empty the line;
  - handle the valve to put down the residue pressure contained inside the space between the ball and the body before of remove it from the line;
- during the disassembly apply the screw tool at the end of the valve nearest the pipe;

## MAINTENANCE

Verify the valve periodically, according to its application's field and its works' field and its work's conditions, in order to be sure that the valve works correctly.

## WARNINGS

- any deterioration or destruction of any part of the manually operated ball valve shall result in the need to replace complete valve: alterations to any part of the complete valve shall result in the valve no longer being in compliance with the performance requirements of EN 331 standard;
- ensure that the manually operated ball valve allows an adequate flow rate for its intended use;
- all installations should be performed in accordance with existing local installation regulations and codes of practice where they exist;
- it is imperative to follow the installation instructions of the manually operated ball valve manufacturer and of the appliance manufacturer, including those for the correct position of the connection point for the valve.

## MANUFACTURER

ITAP S.p.A.

via Ruca 19/21 - 25065

Lumezzane (BS), Italy

Телефон: +39 030 8927011

Факс: +39 030 8921990

email: [info@itap.it](mailto:info@itap.it)

web: [www.itap.it](http://www.itap.it)



# ПОЛНОПРОХОДНОЙ ШАРОВЫЕ КРАНЫ ДЛЯ ГАЗА: LONDON

## LOSS DIAGRAM (With water) size 1/4" through 2"

	1/4"	3/8"	1/2"	3/4"	1"	1"1/4"	1"1/2"	2"	3"	2"1/2"	4"
<b>KV</b>	3,45	5,00	15,65	26,26	41,44	63,69	101	169	472	376	892

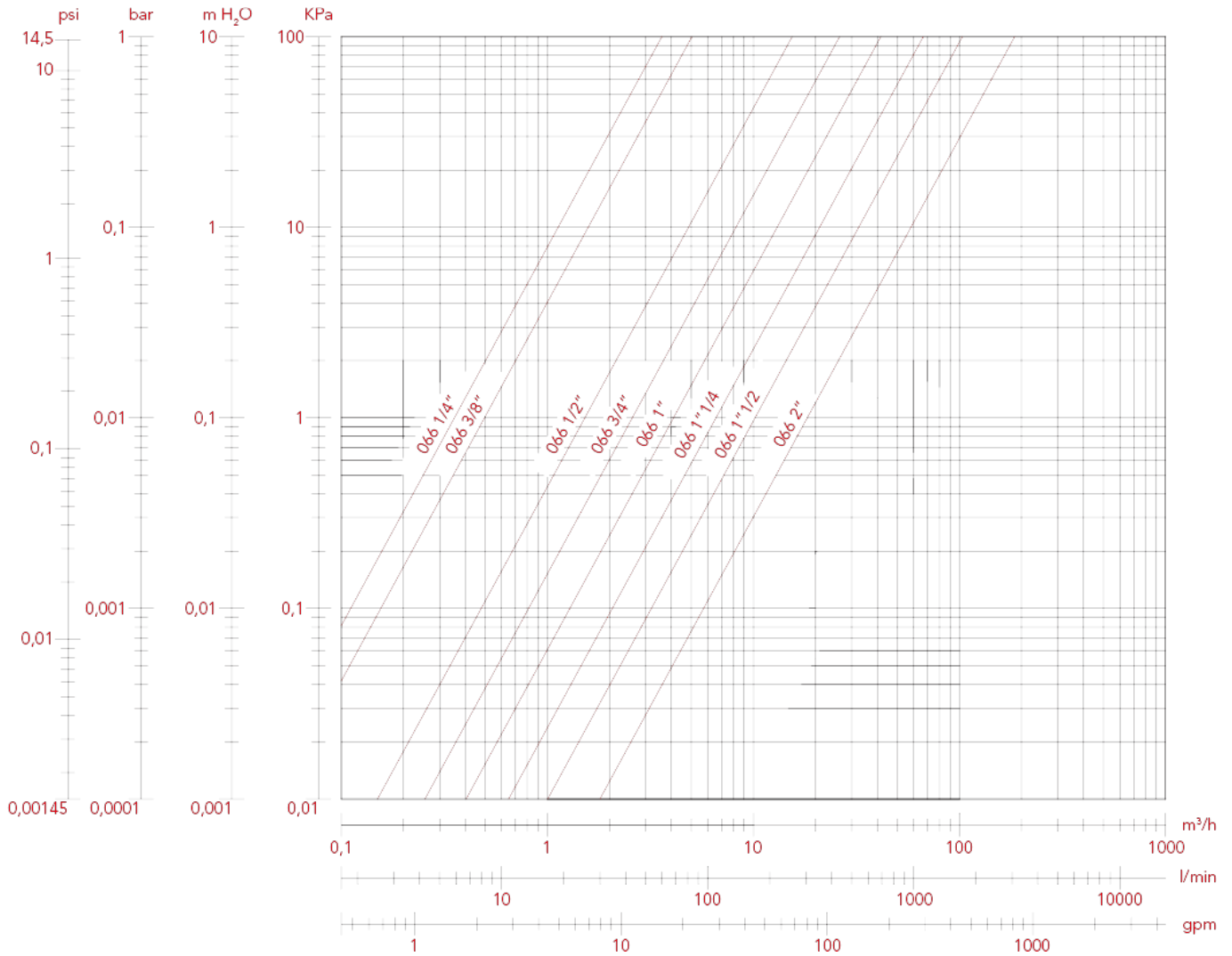



# ПОЛНОПРОХОДНОЙ ШАРОВЫЕ КРАНЫ ДЛЯ ГАЗА: LONDON

## LOSS DIAGRAM (With water) size 2"1/2 through 4"

	1/4"	3/8"	1/2"	3/4"	1"	1"1/4"	1"1/2"	2"	3"	2"1/2"	4"
<b>KV</b>	3,45	5,00	15,65	26,26	41,44	63,69	101	169	472	376	892

	3,45	5,00	15,65	26,26	41,44	63,69	101	169	472	376	892
<b>KV</b>	3,45	5,00	15,65	26,26	41,44	63,69	101	169	472	376	892

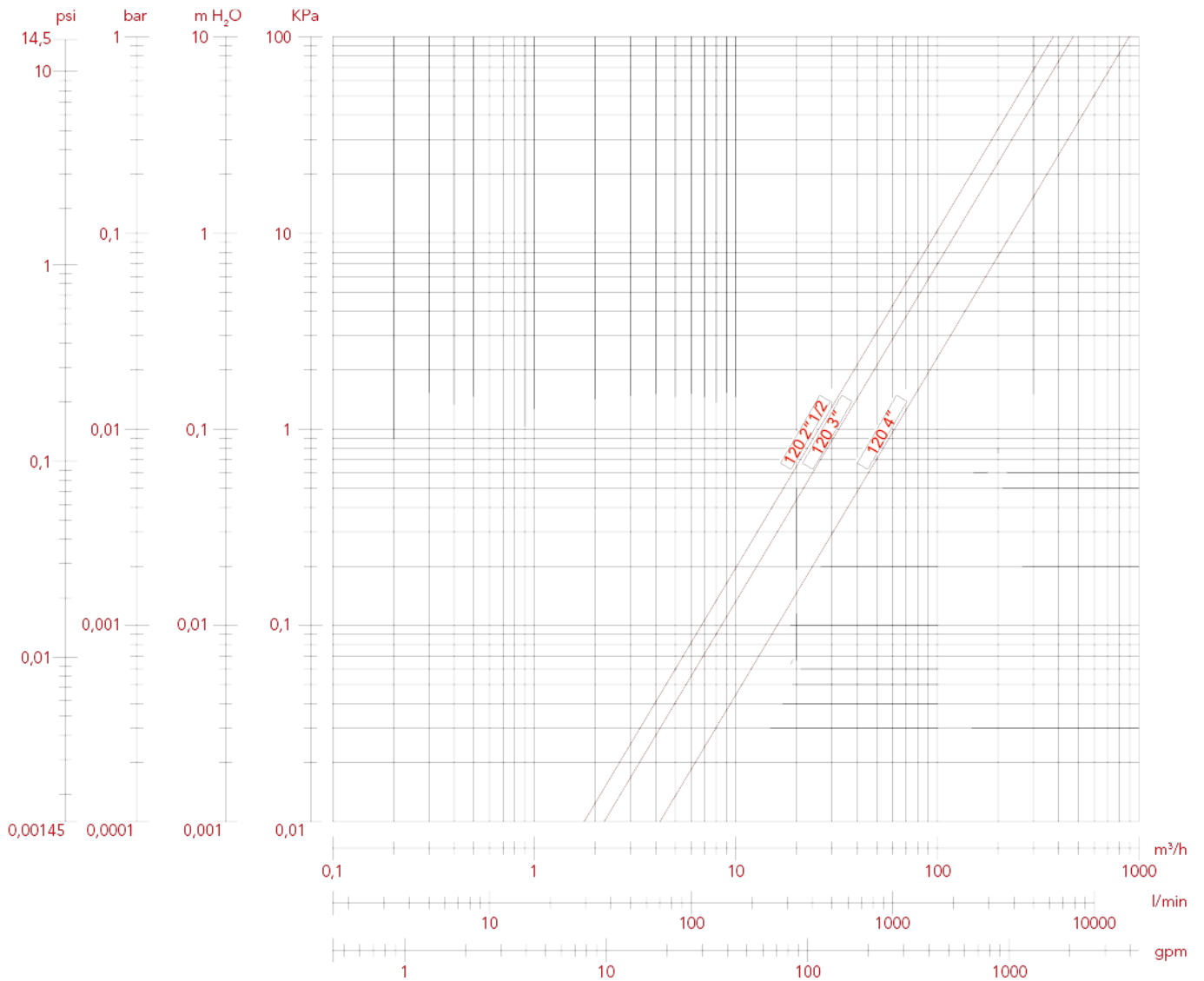



# ПОЛНОПРОХОДНОЙ ШАРОВЫЕ КРАНЫ ДЛЯ ГАЗА: LONDON

## PRESSURE-TEMPERATURE DIAGRAM

The values shown by the dropping lines state the maximum limit of employment of the valves.  
The shown values are approximate.

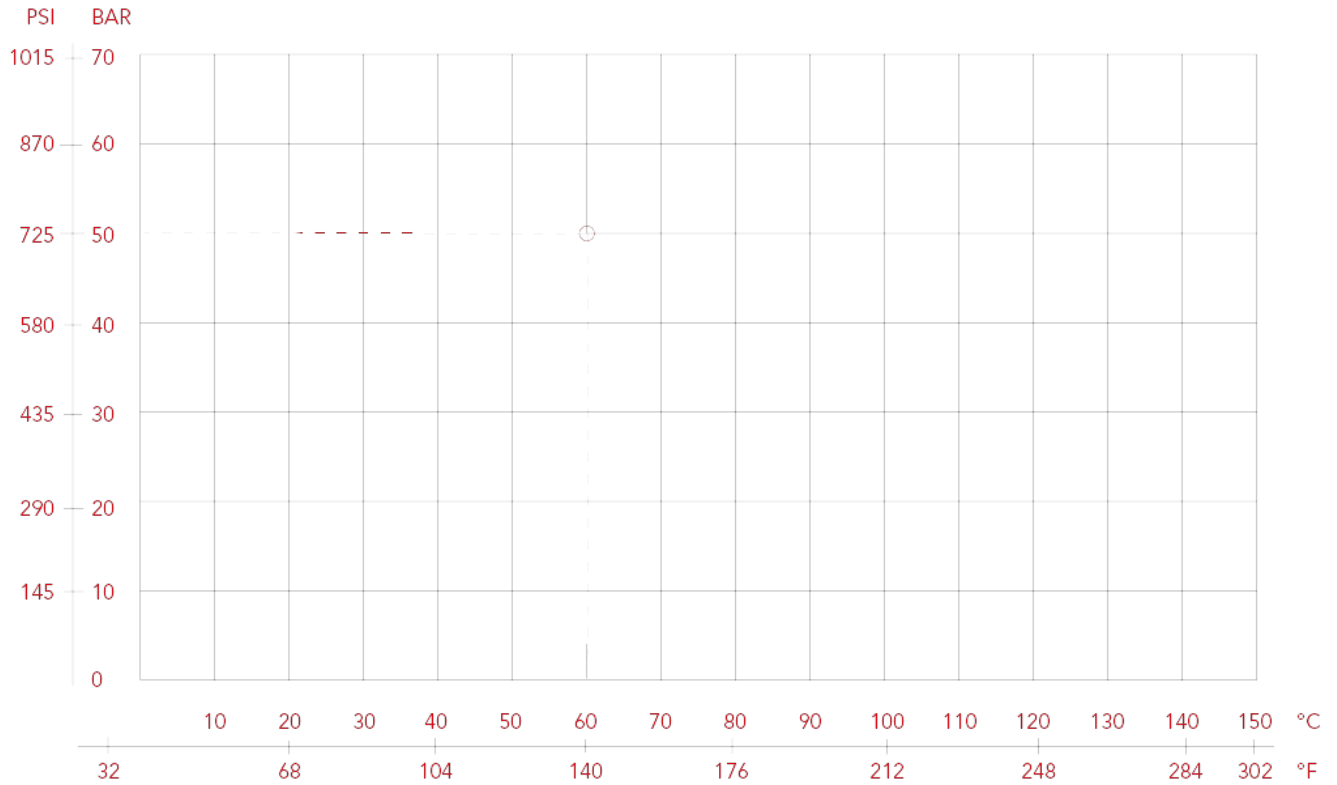



# ПОЛНОПРОХОДНОЙ ШАРОВЫЕ КРАНЫ ДЛЯ ГАЗА: LONDON

## 068 LONDON кран шаровый, полнопроходной

LONDON

ОДОБРЕНО СОГЛАСНО СТАНДАРТА EN 331 (до 2").



РАЗМЕР	ДАВЛЕНИЕ	КОД ИТАР	УПАКОВКА
1/4" (DN 8)	5bar/72.5psi	068B014	15/165
3/8" (DN 10)	5bar/72.5psi	068B038	15/165
1/2" (DN 15)	5bar/72.5psi	068B012	10/110
3/4" (DN 20)	5bar/72.5psi	068B034	8/64
1" (DN 25)	5bar/72.5psi	068B100	6/48

### КАЧЕСТВО



### ОПИСАНИЕ

Резьбы: ВР-ВР или НР-ВР.

Корпус никелированная латунь.

Стальная ручка-рычаг (Алюминиевая ручка-рычаг 2"1/2 - 3" - 4") или Алюминиевая ручка-бабочка или плоский рычаг.

Минимальная и максимальная рабочие температуры: -20°C, 60°C.

ВР:

- ISO 7/1 Rp (эквивалентно DIN EN 10226-1 и BS EN 10226-1) от 1/4" до 2".

- ISO 228 (эквивалентно DIN EN ISO 228 и BS EN ISO 228) 2"1/2 - 3" - 4"

НР:

- ISO 7/1 R (эквивалентно DIN EN 10226-1 и BS EN 10226-1) от 1/4" до 2".

- ISO228 (equivalent to DIN EN ISO 228 and BS EN ISO 228) sizes 2"1/2, 3" and 4"



# ПОЛНОПРОХОДНОЙ ШАРОВЫЕ КРАНЫ ДЛЯ ГАЗА: LONDON

## OVERALL DIMENSIONS

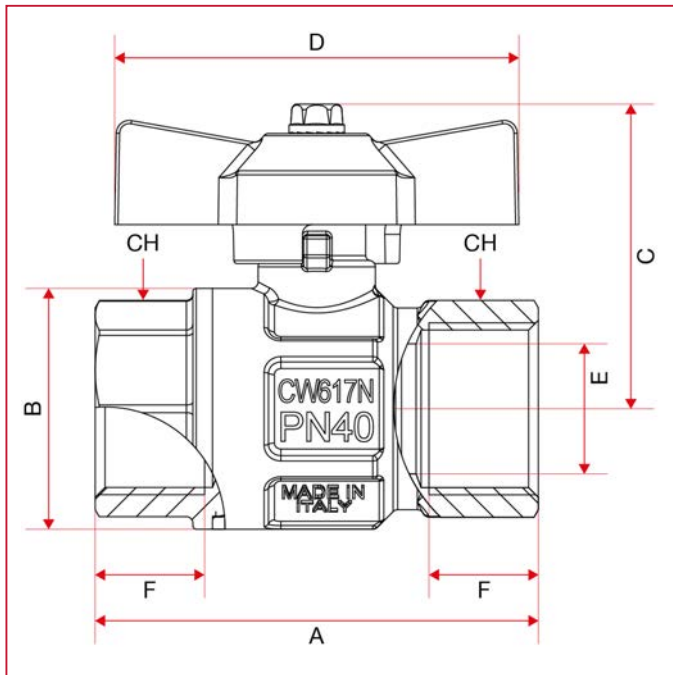

	1/4"	3/8"	1/2"	3/4"	1"
DN	8	10	15	20	25
A	49,5	52,4	61	68	85
B	23,5	24	30,5	37	45,5
C	37,3	37,3	43,8	46,8	50,8
D	47	47	54	62	62
E	10	10	15	20	25
F	11	11,4	15	16,3	19,1
CH	18	21	25	31	38
Kg/cm <sup>2</sup> bar	5	5	5	5	5
LBS - psi	72,5	72,5	72,5	72,5	72,5



# ПОЛНОПРОХОДНОЙ ШАРОВЫЕ КРАНЫ ДЛЯ ГАЗА: LONDON

**MATERIALS sizes 1/4" through 3/8"**

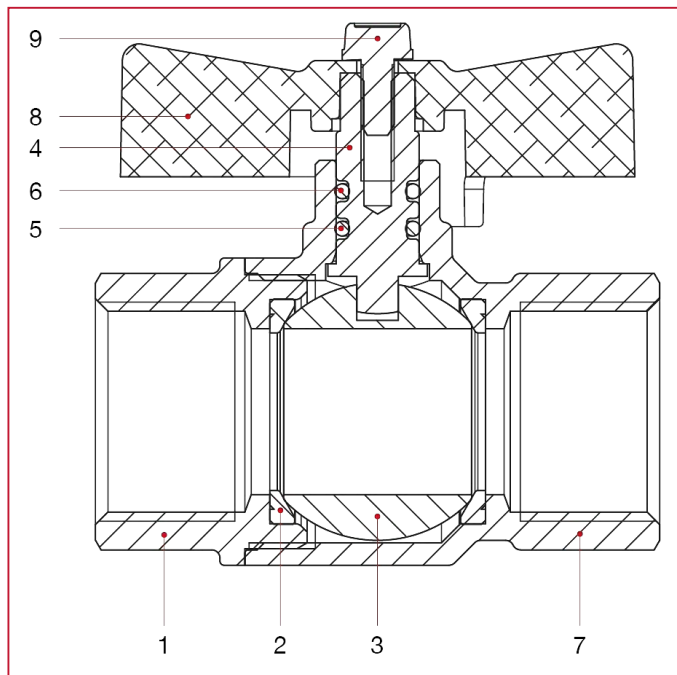

N.	ОПИСАНИЕ	КО Л.	МАТЕРИАЛ
1	Female end adapter	1	Nickel-plated brass CW617N
2	Seat	2	P.T.F.E.
3	Ball	1	Chrome-plated brass CW614N
4	Stem	1	Brass CW614N
5	O-ring	1	NBR
6	O-ring	1	Viton®
7	Body	1	Nickel-plated brass CW617N
8	T handle	1	Varnished aluminium
9	Screw	1	Zinc-plated steel C4C



# ПОЛНОПРОХОДНОЙ ШАРОВЫЕ КРАНЫ ДЛЯ ГАЗА: LONDON

MATERIALS sizes 1/2" through 1"

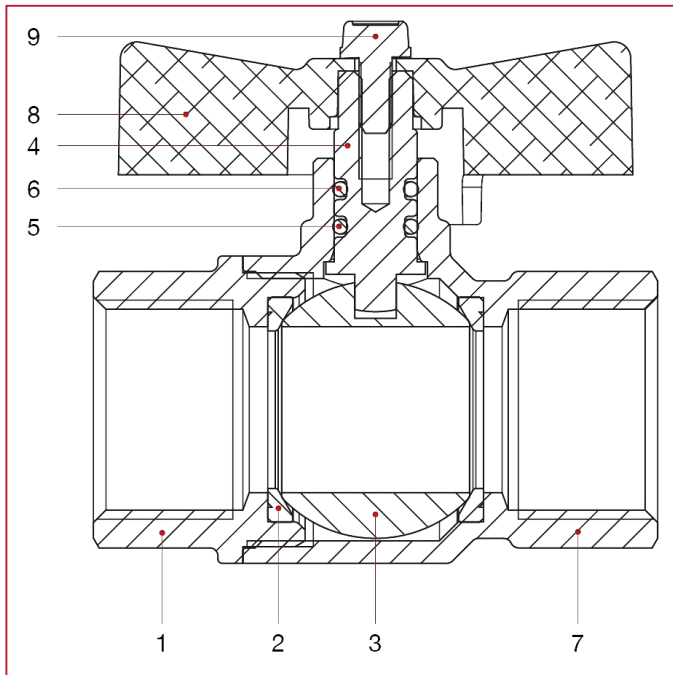

N.	ОПИСАНИЕ	КО Л.	МАТЕРИАЛ
1	Female end adapter	1	Nickel-plated brass CW617N
2	Seat	2	P.T.F.E.
3	Ball	1	Chrome-plated brass CW617N
4	Stem	1	Brass CW614N
5	O-ring	1	NBR
6	O-ring	1	Viton®
7	Body	1	Nickel-plated brass CW617N
8	T handle	1	Varnished aluminium
9	Screw	1	Zinc-plated steel C4C





# ПОЛНОПРОХОДНОЙ ШАРОВЫЕ КРАНЫ ДЛЯ ГАЗА: LONDON

## INSTALLATION

The itap S.p.A.'s valves are bi-directional, that means they manage the flow in both the directions.

The valves are composed by a ball, two seal in PTFE material, one stem, two sailing rings (O-Rings), one handle and a couple of parts made of brass (body and end adapter) that contain them and that are assembled by means of thread and a sealed material to obtain their aim.

In order to avoid that the sealed material gets broken and then the valve loses the connection between the body and the end-adaptor, it's necessary to avoid to submit the two parts under the influence of a torque.

For the installation normal hydraulic practices must be used, and especially:

- ones have to be sure that the two pipes are correctly aligned;
- during the assembling process the installer has to apply its assembling tools at the end that is nearest to the pipe;
- the application of the sealing materials by the fitter (PTFE or hempen cloth) must be limited at the thread zone. An excess should interfere in the ball-gasket's closure zone, compromising the tightness.
- in the case that the fluid transported presents some impurities (dust, water too hard, etc.) ones have to remove these impurities by the means of a filter. Otherwise they could damage the seals.

## DISASSEMBLY

To remove the valve from the pipe line or anyhow before to unscrew the junctions linked to it:

- wear the clothing protective normally required to work with the fluid transported within the line;
- depressurize the line and operate in this way:
  - positioning the valve in opened position and then empty the line;
  - handle the valve to put down the residue pressure contained inside the space between the ball and the body before of remove it from the line;
- during the disassembly apply the screw tool at the end of the valve nearest the pipe;

## MAINTENANCE

Verify the valve periodically, according to its application's field and its works' field and its work's conditions, in order to be sure that the valve works correctly.

## WARNINGS

- any deterioration or destruction of any part of the manually operated ball valve shall result in the need to replace complete valve: alterations to any part of the complete valve shall result in the valve no longer being in compliance with the performance requirements of EN 331 standard;
- ensure that the manually operated ball valve allows an adequate flow rate for its intended use;
- all installations should be performed in accordance with existing local installation regulations and codes of practice where they exist;
- it is imperative to follow the installation instructions of the manually operated ball valve manufacturer and of the appliance manufacturer, including those for the correct position of the connection point for the valve.

## MANUFACTURER

ITAP S.p.A.

via Ruca 19/21 - 25065

Lumezzane (BS), Italy

Телефон: +39 030 8927011

Факс: +39 030 8921990

email: [info@itap.it](mailto:info@itap.it)

web: [www.itap.it](http://www.itap.it)



# ПОЛНОПРОХОДНОЙ ШАРОВЫЕ КРАНЫ ДЛЯ ГАЗА: LONDON

## LOSS DIAGRAM (With water)

	1/4"	3/8"	1/2"	3/4"	1"
KV	3,45	5,00	15,65	26,26	41,44

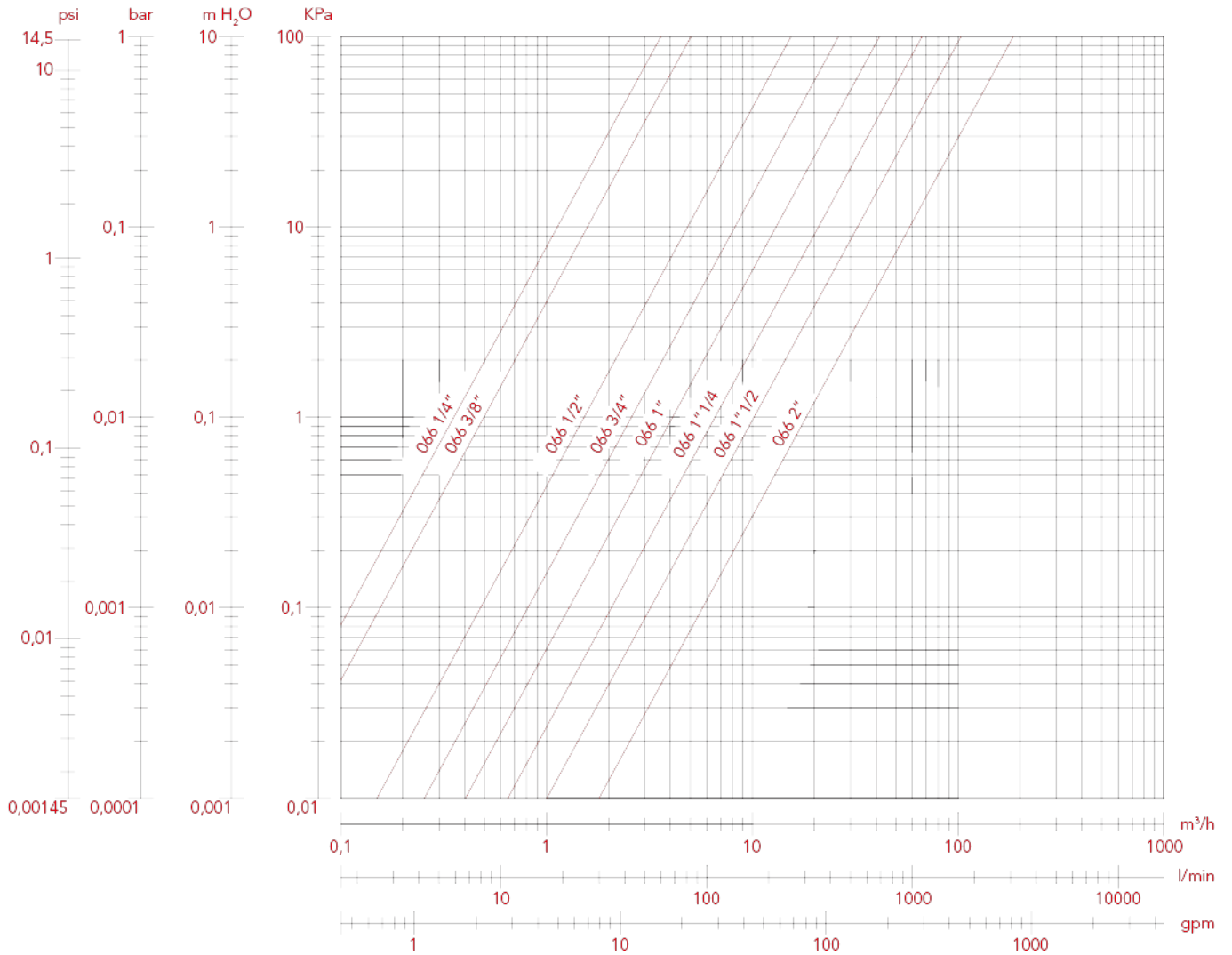



# ПОЛНОПРОХОДНОЙ ШАРОВЫЕ КРАНЫ ДЛЯ ГАЗА: LONDON

## PRESSURE-TEMPERATURE DIAGRAM

The values shown by the dropping lines state the maximum limit of employment of the valves.  
The shown values are approximate.

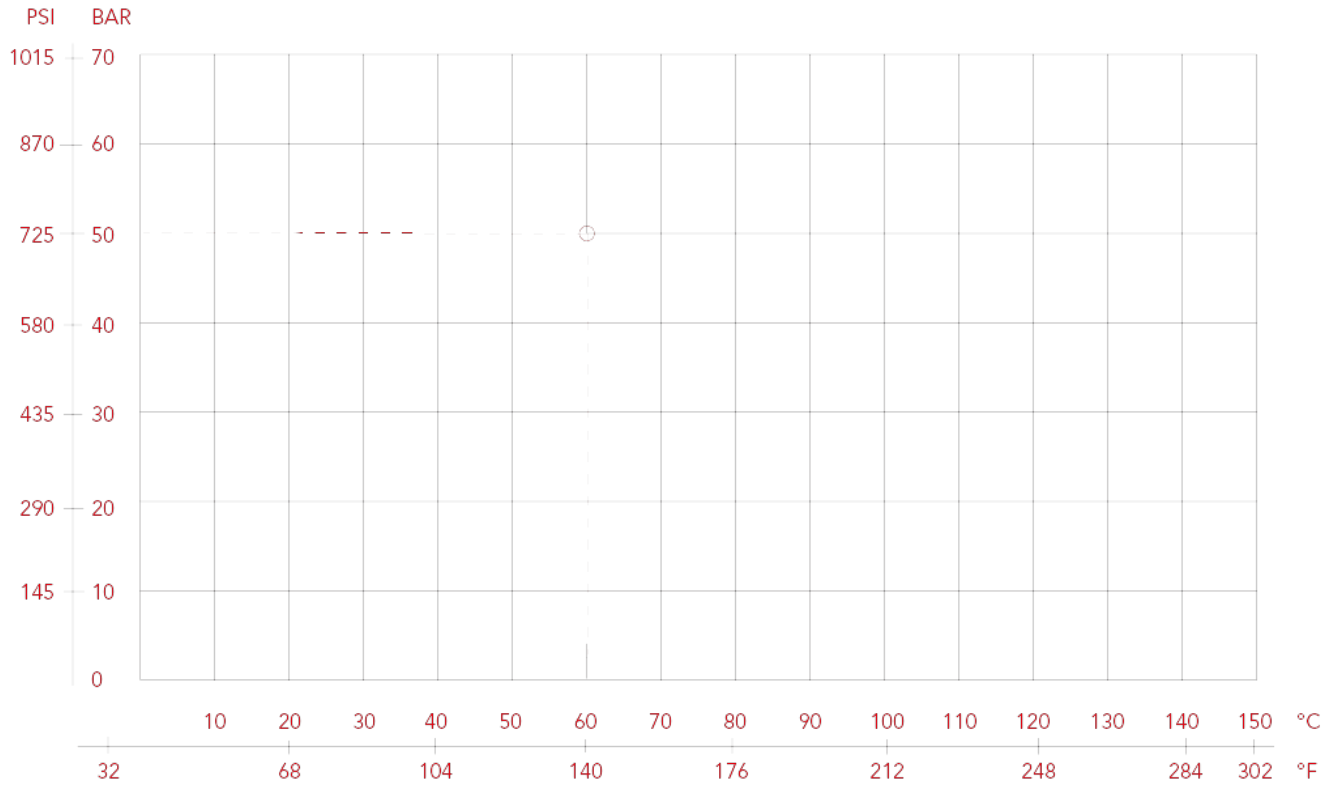



# ПОЛНОПРОХОДНОЙ ШАРОВЫЕ КРАНЫ ДЛЯ ГАЗА: LONDON

## 069 LONDON кран шаровый, полнопроходной

LONDON

ОДОБРЕНО СОГЛАСНО СТАНДАРТА EN 331 (до 2").



РАЗМЕР	ДАВЛЕНИЕ	КОД ИТАР	УПАКОВКА
1/4" (DN 8)	5bar/72.5psi	069B014	15/165
3/8" (DN 10)	5bar/72.5psi	069B038	15/165
1/2" (DN 15)	5bar/72.5psi	069B012	10/130
3/4" (DN 20)	5bar/72.5psi	069B034	8/64
1" (DN 25)	5bar/72.5psi	069B100	6/48

### КАЧЕСТВО



### ОПИСАНИЕ

Резьбы: ВР-ВР или НР-ВР.

Корпус никелированная латунь.

Стальная ручка-рычаг (Алюминиевая ручка-рычаг 2"1/2 - 3" - 4") или Алюминиевая ручка-бабочка или плоский рычаг.

Минимальная и максимальная рабочие температуры: -20°C, 60°C.

ВР:

- ISO 7/1 Rp (эквивалентно DIN EN 10226-1 и BS EN 10226-1) от 1/4" до 2".

- ISO 228 (эквивалентно DIN EN ISO 228 и BS EN ISO 228) 2"1/2 - 3" - 4"

НР:

- ISO 7/1 R (эквивалентно DIN EN 10226-1 и BS EN 10226-1) от 1/4" до 2".

- ISO228 (equivalent to DIN EN ISO 228 and BS EN ISO 228) sizes 2"1/2, 3" and 4"



# ПОЛНОПРОХОДНОЙ ШАРОВЫЕ КРАНЫ ДЛЯ ГАЗА: LONDON

## OVERALL DIMENSIONS

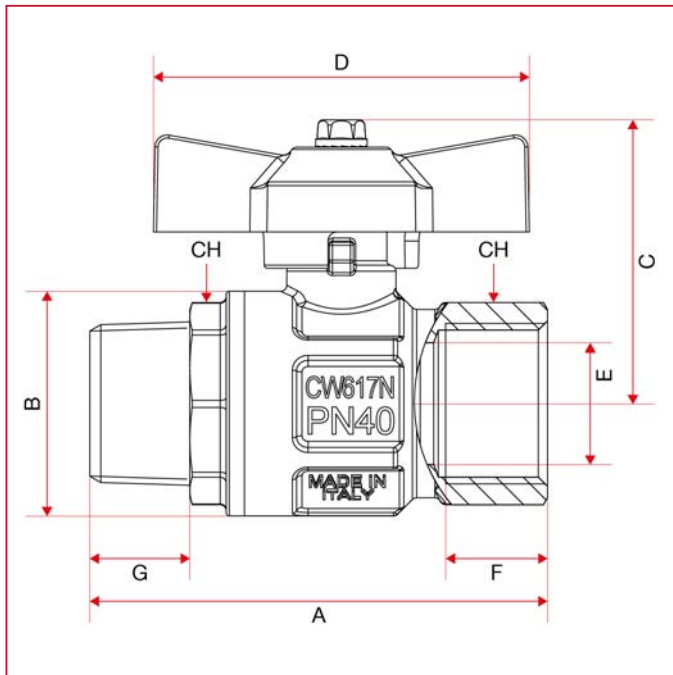

	1/4"	3/8"	1/2"	3/4"	1"
DN	8	10	15	20	25
A	56,9	58,9	68	75,5	90,5
B	23,5	24	30,5	37	45,5
C	37,3	37,3	43,8	46,8	50,8
D	47	47	54	62	62
E	8	10	15	20	25
F	11	11,4	15	16,3	19,1
G	11	11,5	15	16,5	19
CH	18	21	25	31	38
Kg/cm <sup>2</sup> bar	5	5	5	5	5
LBS - psi	72,5	72,5	72,5	72,5	72,5



# ПОЛНОПРОХОДНОЙ ШАРОВЫЕ КРАНЫ ДЛЯ ГАЗА: LONDON

**MATERIALS sizes 1/4" through 3/8"**

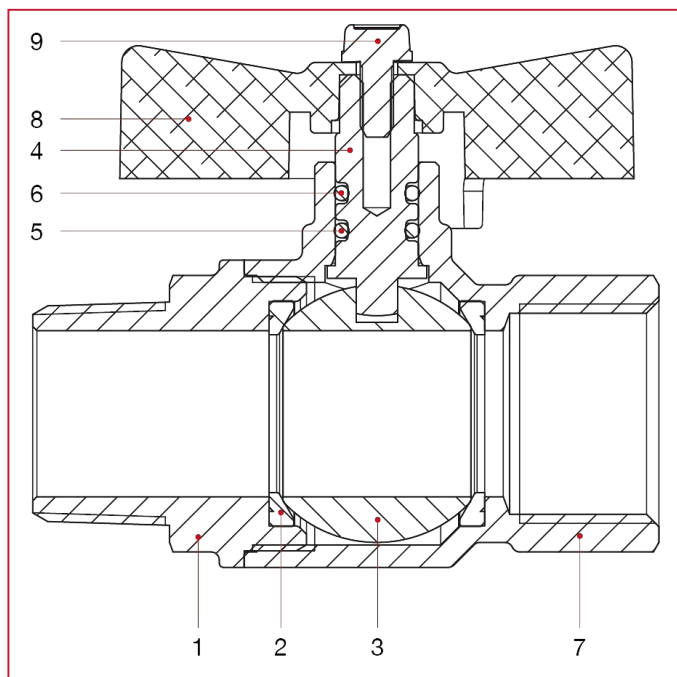

N.	ОПИСАНИЕ	КО Л.	МАТЕРИАЛ
1	Male end adapter	1	Nickel-plated brass CW617N
2	Seat	2	P.T.F.E.
3	Ball	1	Chrome-plated brass CW614N
4	Stem	1	Brass CW614N
5	O-ring	1	NBR
6	O-ring	1	Viton®
7	Body	1	Nickel-plated brass CW617N
8	T handle	1	Varnished aluminium
9	Screw	1	Zinc-plated steel C4C



# ПОЛНОПРОХОДНОЙ ШАРОВЫЕ КРАНЫ ДЛЯ ГАЗА: LONDON

MATERIALS sizes 1/2" through 1"

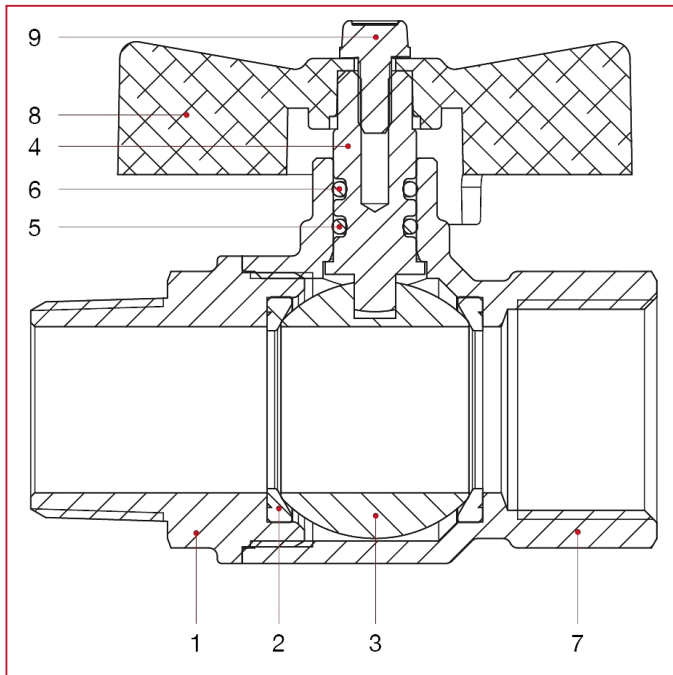

N.	ОПИСАНИЕ	КО Л.	МАТЕРИАЛ
1	Male end adapter	1	Nickel-plated brass CW617N
2	Seat	2	P.T.F.E.
3	Ball	1	Chrome-plated brass CW617N
4	Stem	1	Brass CW614N
5	O-ring	1	NBR
6	O-ring	1	Viton®
7	Body	1	Nickel-plated brass CW617N
8	T handle	1	Varnished aluminium
9	Screw	1	Zinc-plated steel C4C



# ПОЛНОПРОХОДНОЙ ШАРОВЫЕ КРАНЫ ДЛЯ ГАЗА: LONDON

## INSTALLATION

The itap S.p.A.'s valves are bi-directional, that means they manage the flow in both the directions.

The valves are composed by a ball, two seal in PTFE material, one stem, two sailing rings (O-Rings), one handle and a couple of parts made of brass (body and end adapter) that contain them and that are assembled by means of thread and a sealed material to obtain their aim.

In order to avoid that the sealed material gets broken and then the valve loses the connection between the body and the end adapter, it's necessary to avoid to submit the two parts under the influence of a torque.

For the installation normal hydraulic practices must be used, and especially:

- ones have to be sure that the two pipes are correctly aligned;
- during the assembling process the installer has to apply its assembling tools at the end that is nearest to the pipe;
- the application of the sealing materials by the fitter (PTFE or hempen cloth) must be limited at the thread zone. An excess should interfere in the ball-gasket's closure zone, compromising the tightness.
- in the case that the fluid transported presents some impurities (dust, water too hard, etc.) ones have to remove these impurities by the means of a filter. Otherwise they could damage the seals.

## DISASSEMBLY

To remove the valve from the pipe line or anyhow before to unscrew the junctions linked to it:

- wear the clothing protective normally required to work with the fluid transported within the line;
- depressurize the line and operate in this way:
  - positioning the valve in opened position and then empty the line;
  - handle the valve to put down the residue pressure contained inside the space between the ball and the body before of remove it from the line;
- during the disassembly apply the screw tool at the end of the valve nearest the pipe;

## MAINTENANCE

Verify the valve periodically, according to its application's field and its works' field and its work's conditions, in order to be sure that the valve works correctly.

## WARNINGS

- any deterioration or destruction of any part of the manually operated ball valve shall result in the need to replace complete valve: alterations to any part of the complete valve shall result in the valve no longer being in compliance with the performance requirements of EN 331 standard;
- ensure that the manually operated ball valve allows an adequate flow rate for its intended use;
- all installations should be performed in accordance with existing local installation regulations and codes of practice where they exist;
- it is imperative to follow the installation instructions of the manually operated ball valve manufacturer and of the appliance manufacturer, including those for the correct position of the connection point for the valve.

## MANUFACTURER

ITAP S.p.A.

via Ruca 19/21 - 25065

Lumezzane (BS), Italy

Телефон: +39 030 8927011

Факс: +39 030 8921990

email: [info@itap.it](mailto:info@itap.it)

web: [www.itap.it](http://www.itap.it)





# ПОЛНОПРОХОДНОЙ ШАРОВЫЕ КРАНЫ ДЛЯ ГАЗА: LONDON

## LOSS DIAGRAM (With water)

	1/4"	3/8"	1/2"	3/4"	1"
KV	3,45	5,00	15,65	26,26	41,44

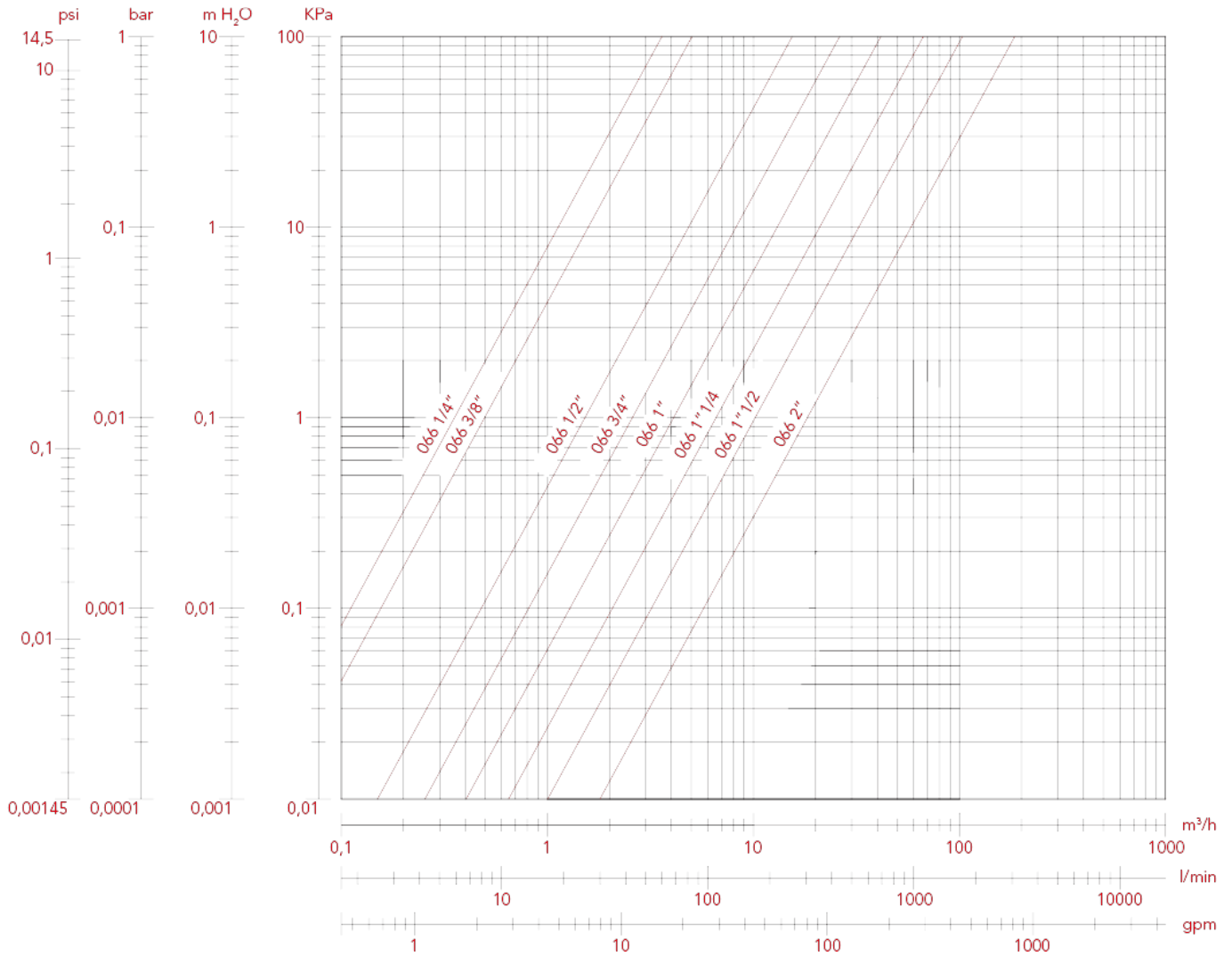



# ПОЛНОПРОХОДНОЙ ШАРОВЫЕ КРАНЫ ДЛЯ ГАЗА: LONDON

## PRESSURE-TEMPERATURE DIAGRAM

The values shown by the dropping lines state the maximum limit of employment of the valves.  
The shown values are approximate.

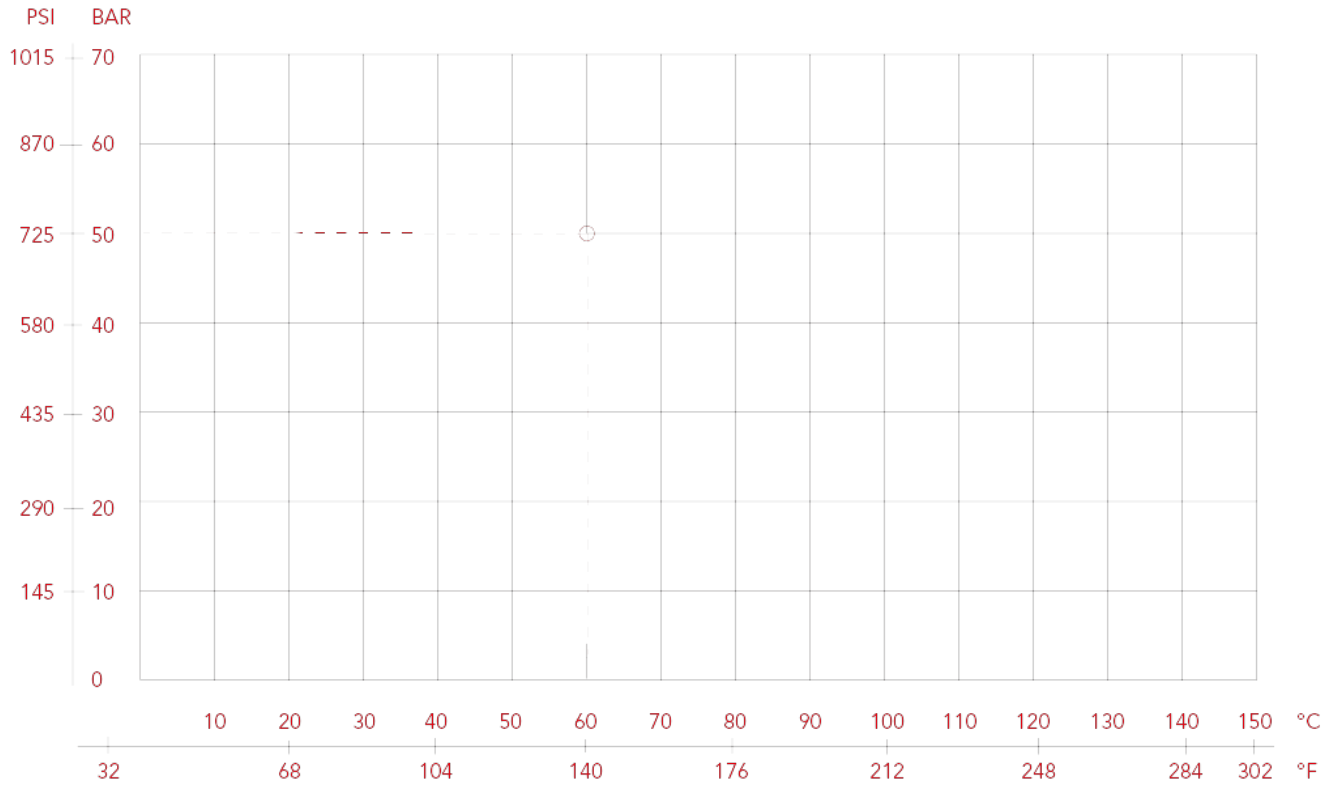



# ПОЛНОПРОХОДНОЙ ШАРОВЫЕ КРАНЫ ДЛЯ ГАЗА: LONDON

## 266 LONDON кран шаровый, полнопроходной

LONDON

ОДОБРЕНО СОГЛАСНО СТАНДАРТА EN 331 (до 2").



РАЗМЕР	ДАВЛЕНИЕ	КОД ИТАР	УПАКОВКА
1/4" (DN 8)	5bar/72.5psi	266B014	12/156
3/8" (DN 10)	5bar/72.5psi	266B038	12/156
1/2" (DN 15)	5bar/72.5psi	266B012	10/80
3/4" (DN 20)	5bar/72.5psi	266B034	8/64
1" (DN 25)	5bar/72.5psi	266B100	6/48
1"1/4 (DN 32)	5bar/72.5psi	266B114	4/24
1"1/2 (DN 40)	5bar/72.5psi	266B112	2/18
2" (DN 50)	5bar/72.5psi	266B200	2/14

### КАЧЕСТВО



### ОПИСАНИЕ

Резьбы: ВР-ВР или НР-ВР.

Корпус никелированная латунь.

Стальная ручка-рычаг (Алюминиевая ручка-рычаг 2"1/2 - 3" - 4") или Алюминиевая ручка-бабочка или плоский рычаг.

Минимальная и максимальная рабочие температуры: -20°C, 60°C.

ВР:

- ISO 7/1 Rp (эквивалентно DIN EN 10226-1 и BS EN 10226-1) от 1/4" до 2".

- ISO 228 (эквивалентно DIN EN ISO 228 и BS EN ISO 228) 2"1/2 - 3" - 4"

НР:

- ISO 7/1 R (эквивалентно DIN EN 10226-1 и BS EN 10226-1) от 1/4" до 2".

- ISO228 (equivalent to DIN EN ISO 228 and BS EN ISO 228) sizes 2"1/2, 3" and 4"



# ПОЛНОПРОХОДНОЙ ШАРОВЫЕ КРАНЫ ДЛЯ ГАЗА: LONDON

## OVERALL DIMENSIONS

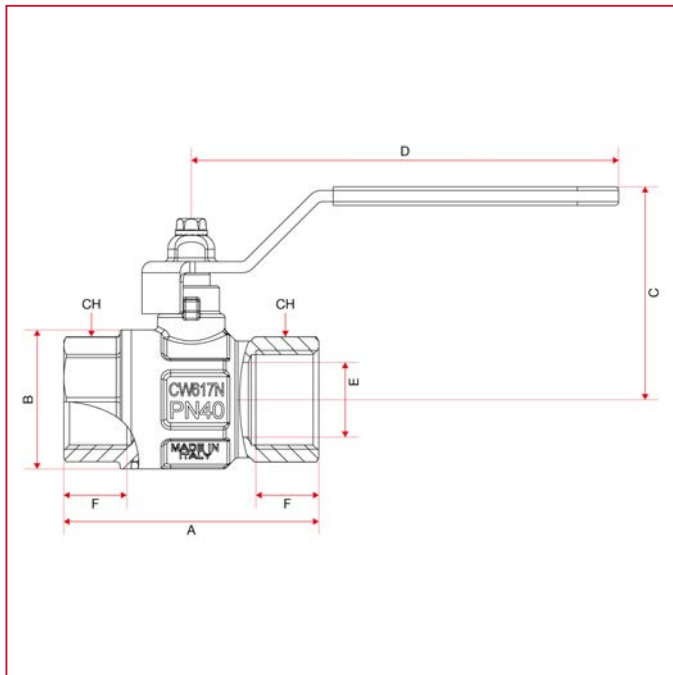

	1/4"	3/8"	1/2"	3/4"	1"	1"1/4	1"1/2	2"
DN	8	10	15	20	25	32	40	50
A	49,5	52,4	61	68	85	99,5	109	130
B	23,5	24	30,5	37	45,5	58	71	85
C	42,3	42,3	50,8	56,8	60,8	76,8	92,3	99,3
D	86	86	93	114	114	138,5	158,5	158,5
E	10	10	15	20	25	32	40	50
F	11	11,4	15	16,3	19,1	21,4	21,4	25,7
CH	18	21	25	31	38	47	54	66
Kg/cm <sup>2</sup> bar	5	5	5	5	5	5	5	5
LBS - psi	72,5	72,5	72,5	72,5	72,5	72,5	72,5	72,5



# ПОЛНОПРОХОДНОЙ ШАРОВЫЕ КРАНЫ ДЛЯ ГАЗА: LONDON

**MATERIALS sizes 1/4" through 3/8"**

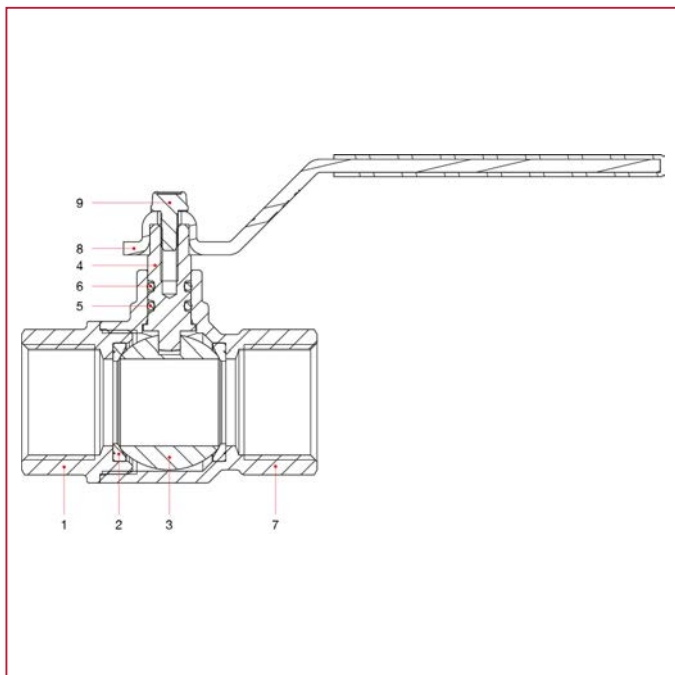

N.	ОПИСАНИЕ	КО Л.	МАТЕРИАЛ
1	Female end adapter	1	Nickel-plated brass CW617N
2	Seat	2	P.T.F.E.
3	Ball	1	Chrome-plated brass CW614N
4	Stem	1	Brass CW614N
5	O-ring	1	NBR
6	O-ring	1	Viton®
7	Body	1	Nickel-plated brass CW617N
8	Flat lever handle	1	Zinc-plated and plastic coated steel P04
9	Screw	1	Zinc-plated steel C4C



# ПОЛНОПРОХОДНОЙ ШАРОВЫЕ КРАНЫ ДЛЯ ГАЗА: LONDON

**MATERIALS sizes 1/2" through 2"**

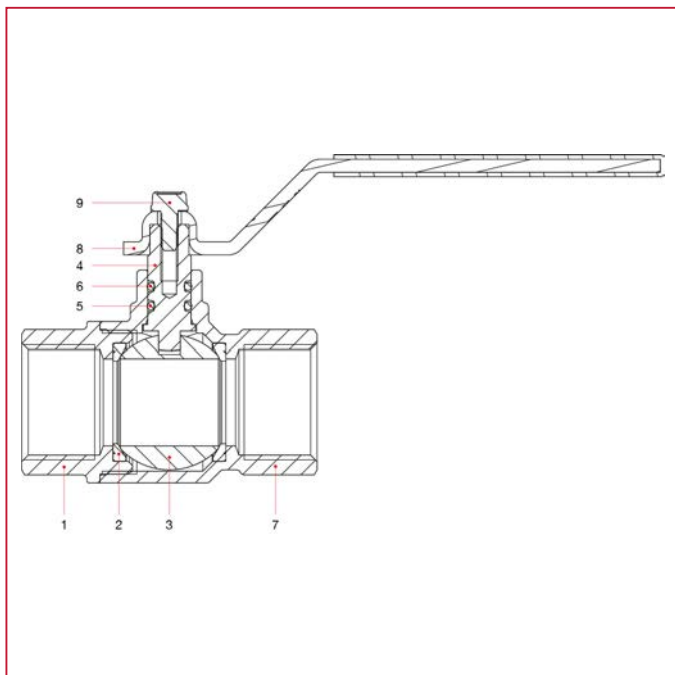

N.	ОПИСАНИЕ	КО Л.	МАТЕРИАЛ
1	Female end adapter	1	Nickel-plated brass CW617N
2	Seat	2	P.T.F.E.
3	Ball	1	Chrome-plated brass CW617N
4	Stem	1	Brass CW614N
5	O-ring	1	NBR
6	O-ring	1	Viton®
7	Body	1	Nickel-plated brass CW617N
8	Flat lever handle	1	Zinc-plated and plastic coated steel P04
9	Screw	1	Zinc-plated steel C4C



# ПОЛНОПРОХОДНОЙ ШАРОВЫЕ КРАНЫ ДЛЯ ГАЗА: LONDON

## INSTALLATION

The itap S.p.A.'s valves are bi-directional, that means they manage the flow in both the directions.

The valves are composed by a ball, two seal in PTFE material, one stem, two sailing rings (O-Rings), one handle and a couple of parts made of brass (body and end adapter) that contain them and that are assembled by means of thread and a sealed material to obtain their aim.

In order to avoid that the sealed material gets broken and then the valve loses the connection between the body and the end adapter, it's necessary to avoid to submit the two parts under the influence of a torque.

For the installation normal hydraulic practices must be used, and especially:

- ones have to be sure that the two pipes are correctly aligned;
- during the assembling process the installer has to apply its assembling tools at the end that is nearest to the pipe;
- the application of the sealing materials by the fitter (PTFE or hempen cloth) must be limited at the thread zone. An excess should interfere in the ball-gasket's closure zone, compromising the tightness.
- in the case that the fluid transported presents some impurities (dust, water too hard, etc.) ones have to remove these impurities by the means of a filter. Otherwise they could damage the seals.

## DISASSEMBLY

To remove the valve from the pipe line or anyhow before to unscrew the junctions linked to it:

- wear the clothing protective normally required to work with the fluid transported within the line;
- depressurize the line and operate in this way:
  - positioning the valve in opened position and then empty the line;
  - handle the valve to put down the residue pressure contained inside the space between the ball and the body before of remove it from the line;
- during the disassembly apply the screw tool at the end of the valve nearest the pipe;

## MAINTENANCE

Verify the valve periodically, according to its application's field and its works' field and its work's conditions, in order to be sure that the valve works correctly.

## WARNINGS

- any deterioration or destruction of any part of the manually operated ball valve shall result in the need to replace complete valve: alterations to any part of the complete valve shall result in the valve no longer being in compliance with the performance requirements of EN 331 standard;
- ensure that the manually operated ball valve allows an adequate flow rate for its intended use;
- all installations should be performed in accordance with existing local installation regulations and codes of practice where they exist;
- it is imperative to follow the installation instructions of the manually operated ball valve manufacturer and of the appliance manufacturer, including those for the correct position of the connection point for the valve.

## MANUFACTURER

ITAP S.p.A.

via Ruca 19/21 - 25065

Lumezzane (BS), Italy

Телефон: +39 030 8927011

Факс: +39 030 8921990

email: [info@itap.it](mailto:info@itap.it)

web: [www.itap.it](http://www.itap.it)



# ПОЛНОПРОХОДНОЙ ШАРОВЫЕ КРАНЫ ДЛЯ ГАЗА: LONDON

## LOSS DIAGRAM (With water)

	1/4"	3/8"	1/2"	3/4"	1"	1"1/4"	1"1/2"	2"
KV	3,45	5,00	15,65	26,26	41,44	63,69	101	169

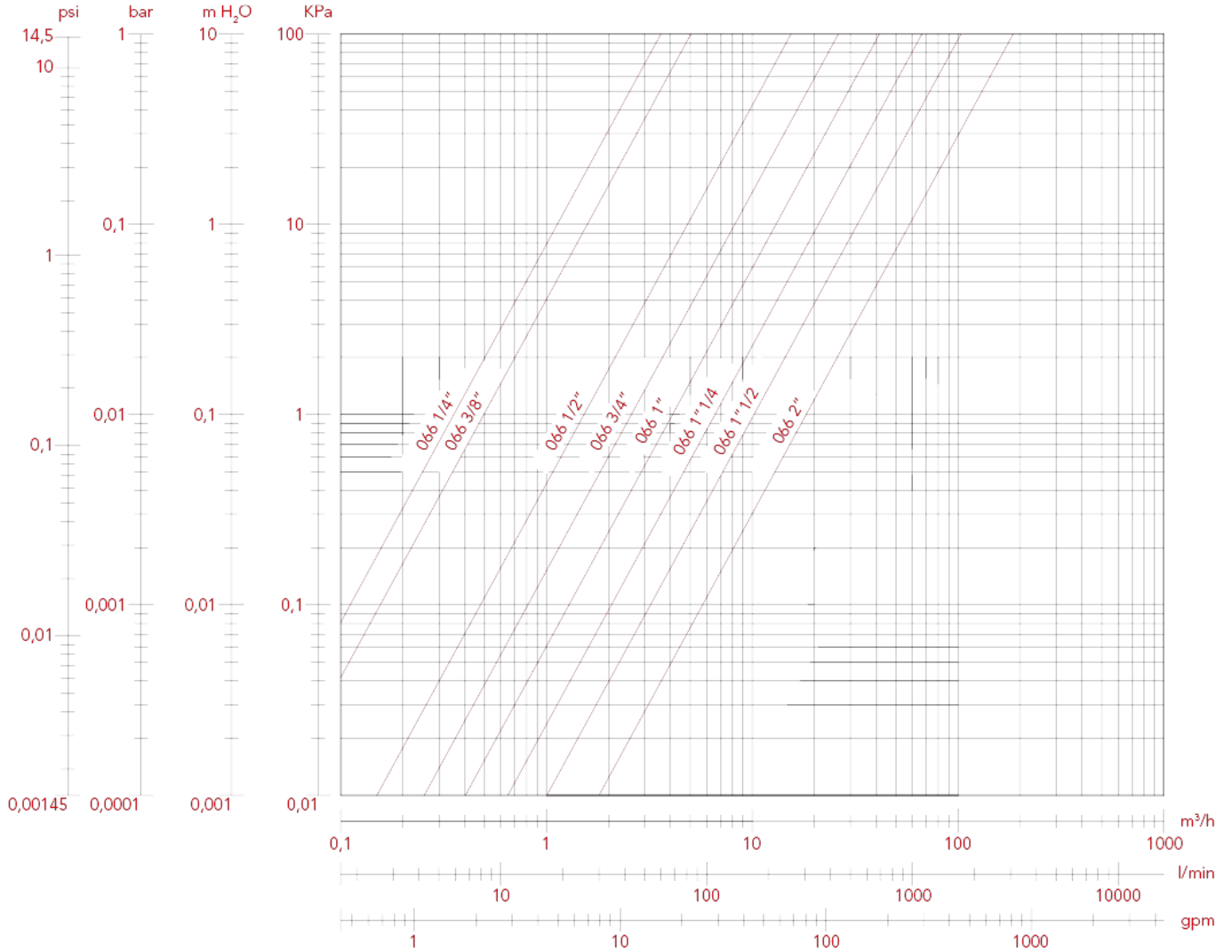





# ПОЛНОПРОХОДНОЙ ШАРОВЫЕ КРАНЫ ДЛЯ ГАЗА: LONDON

## PRESSURE-TEMPERATURE DIAGRAM

The values shown by the dropping lines state the maximum limit of employment of the valves.  
The shown values are approximate.

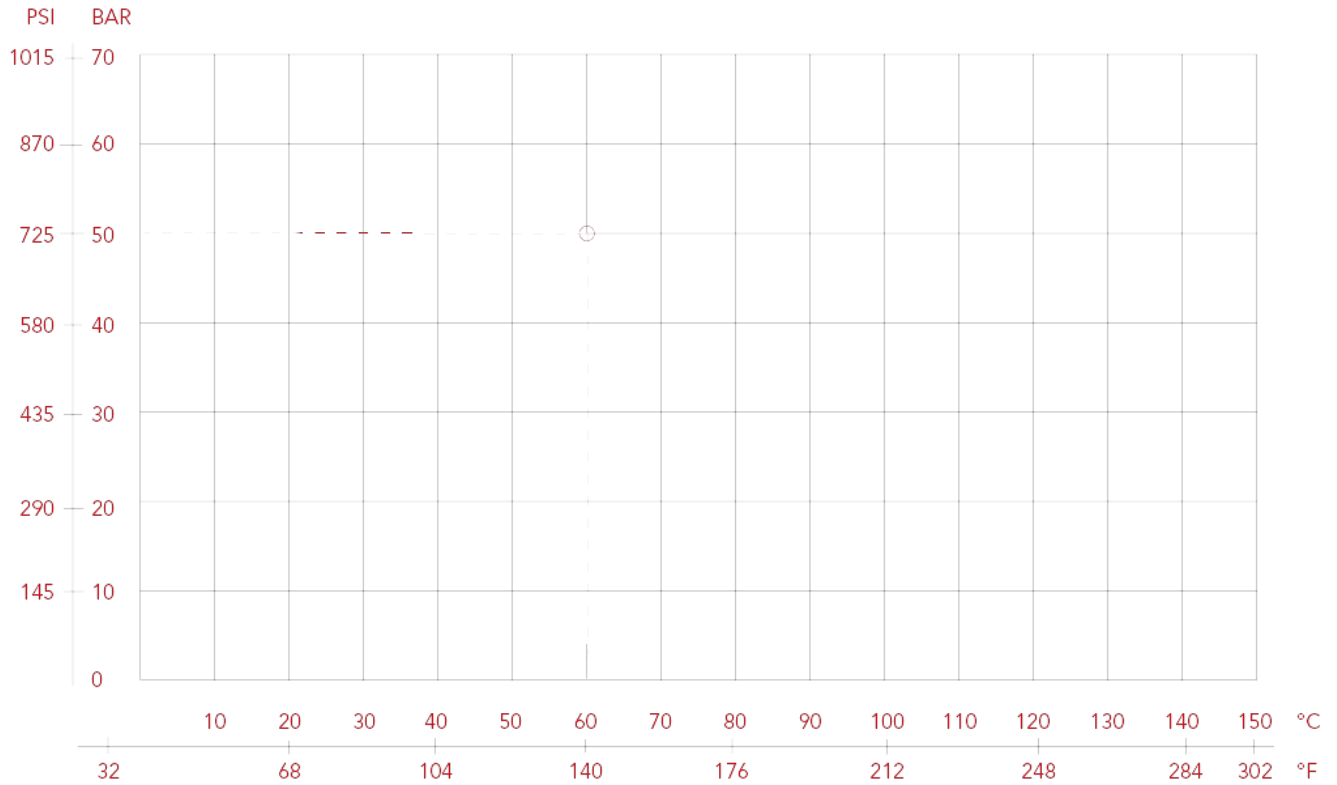



# ПОЛНОПРОХОДНОЙ ШАРОВЫЕ КРАНЫ ДЛЯ ГАЗА: LONDON

## 267 LONDON кран шаровый, полнопроходной

LONDON

ОДОБРЕНО СОГЛАСНО СТАНДАРТА EN 331 (до 2").



РАЗМЕР	ДАВЛЕНИЕ	КОД ИТАР	УПАКОВКА
1/4" (DN 8)	5bar/72.5psi	267B014	12/156
3/8" (DN 10)	5bar/72.5psi	267B038	12/156
1/2" (DN 15)	5bar/72.5psi	267B012	10/80
3/4" (DN 20)	5bar/72.5psi	267B034	8/64
1" (DN 25)	5bar/72.5psi	267B100	6/48
1"1/4 (DN 32)	5bar/72.5psi	267B114	4/24
1"1/2 (DN 40)	5bar/72.5psi	267B112	2/18
2" (DN 50)	5bar/72.5psi	267B200	2/14

### КАЧЕСТВО



### ОПИСАНИЕ

Резьбы: ВР-ВР или НР-ВР.

Корпус никелированная латунь.

Стальная ручка-рычаг (Алюминиевая ручка-рычаг 2"1/2 - 3" - 4") или Алюминиевая ручка-бабочка или плоский рычаг.

Минимальная и максимальная рабочие температуры: -20°C, 60°C.

ВР:

- ISO 7/1 Rp (эквивалентно DIN EN 10226-1 и BS EN 10226-1) от 1/4" до 2".

- ISO 228 (эквивалентно DIN EN ISO 228 и BS EN ISO 228) 2"1/2 - 3" - 4"

НР:

- ISO 7/1 R (эквивалентно DIN EN 10226-1 и BS EN 10226-1) от 1/4" до 2".

- ISO228 (equivalent to DIN EN ISO 228 and BS EN ISO 228) sizes 2"1/2, 3" and 4"



# ПОЛНОПРОХОДНОЙ ШАРОВЫЕ КРАНЫ ДЛЯ ГАЗА: LONDON

## OVERALL DIMENSIONS

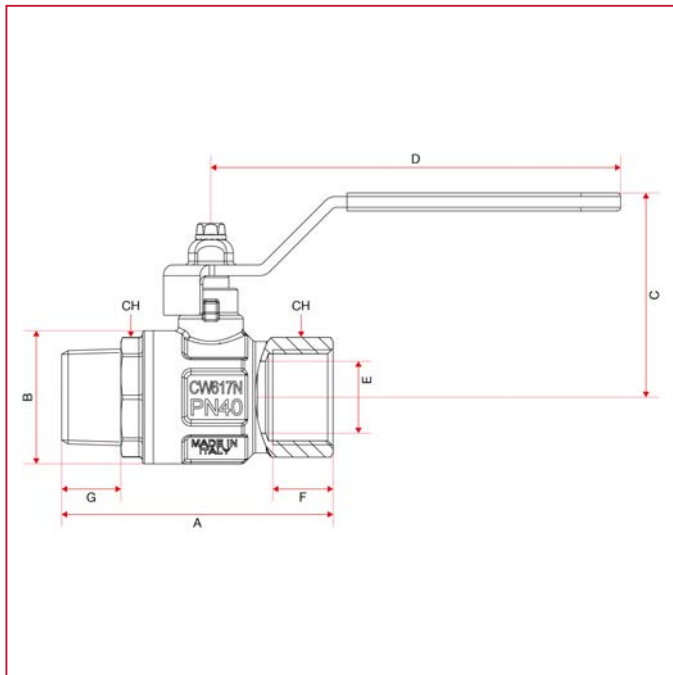

	1/4"	3/8"	1/2"	3/4"	1"	1"1/4	1"1/2	2"
DN	8	10	15	20	25	32	40	50
A	56,9	58,9	68	75,5	90,5	105	115,5	135,5
B	23,5	24	30,5	37	45,5	58	71	85
C	42,3	42,3	50,8	56,8	60,8	76,8	92,3	99,3
D	86	86	93	114	114	138,5	158,5	158,5
E	8	10	15	20	25	32	39	50
F	11	11,4	15	16,3	19,1	21,4	21,4	25,7
G	11	11,5	15	16,5	19	21,5	21,5	26
CH	18	21	25	31	38	47	54	66
Kg/cm <sup>2</sup> bar	5	5	5	5	5	5	5	5
LBS - psi	72,5	72,5	72,5	72,5	72,5	72,5	72,5	72,5



# ПОЛНОПРОХОДНОЙ ШАРОВЫЕ КРАНЫ ДЛЯ ГАЗА: LONDON

**MATERIALS sizes 1/4" through 3/8"**

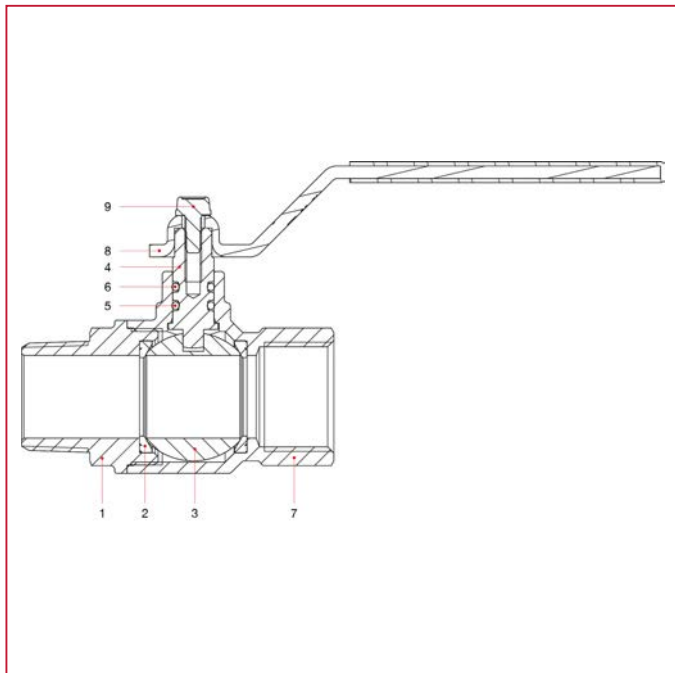

N.	ОПИСАНИЕ	КО Л.	МАТЕРИАЛ
1	Male end adapter	1	Nickel-plated brass CW617N
2	Seat	2	P.T.F.E.
3	Ball	1	Chrome-plated brass CW614N
4	Stem	1	Brass CW614N
5	O-ring	1	NBR
6	O-ring	1	Viton®
7	Body	1	Nickel-plated brass CW617N
8	Flat lever handle	1	Zinc-plated and plastic coated steel P04
9	Screw	1	Zinc-plated steel C4C



# ПОЛНОПРОХОДНОЙ ШАРОВЫЕ КРАНЫ ДЛЯ ГАЗА: LONDON

MATERIALS sizes 1/2" through 2"

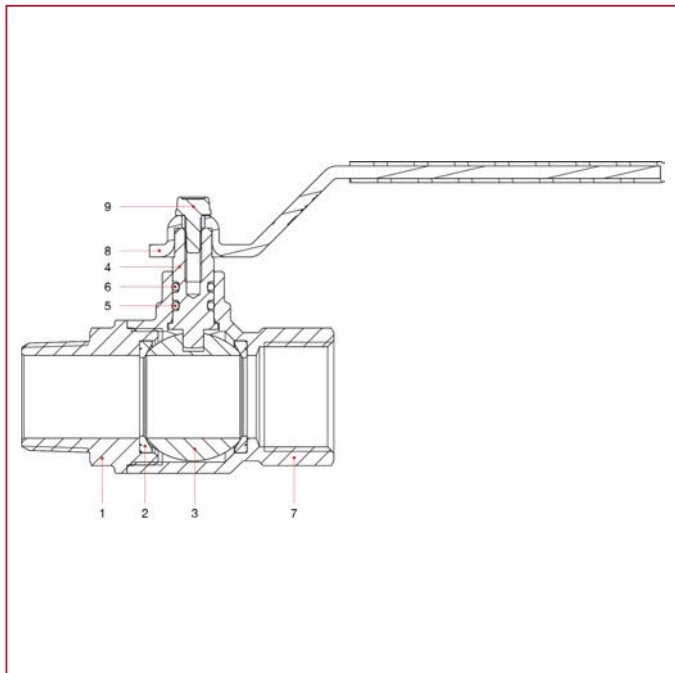

N.	ОПИСАНИЕ	КО Л.	МАТЕРИАЛ
1	Male end adapter	1	Nickel-plated brass CW617N
2	Seat	2	P.T.F.E.
3	Ball	1	Chrome-plated brass CW617N
4	Stem	1	Brass CW614N
5	O-ring	1	NBR
6	O-ring	1	Viton®
7	Body	1	Nickel-plated brass CW617N
8	Flat lever handle	1	Zinc-plated and plastic coated steel P04
9	Screw	1	Zinc-plated steel C4C



# ПОЛНОПРОХОДНОЙ ШАРОВЫЕ КРАНЫ ДЛЯ ГАЗА: LONDON

## INSTALLATION

The itap S.p.A.'s valves are bi-directional, that means they manage the flow in both the directions.

The valves are composed by a ball, two seal in PTFE material, one stem, two sailing rings (O-Rings), one handle and a couple of parts made of brass (body and end adapter) that contain them and that are assembled by means of thread and a sealed material to obtain their aim.

In order to avoid that the sealed material gets broken and then the valve loses the connection between the body and the end adapter, it's necessary to avoid to submit the two parts under the influence of a torque.

For the installation normal hydraulic practices must be used, and especially:

- ones have to be sure that the two pipes are correctly aligned;
- during the assembling process the installer has to apply its assembling tools at the end that is nearest to the pipe;
- the application of the sealing materials by the fitter (PTFE or hempen cloth) must be limited at the thread zone. An excess should interfere in the ball-gasket's closure zone, compromising the tightness.
- in the case that the fluid transported presents some impurities (dust, water too hard, etc.) ones have to remove these impurities by the means of a filter. Otherwise they could damage the seals.

## DISASSEMBLY

To remove the valve from the pipe line or anyhow before to unscrew the junctions linked to it:

- wear the clothing protective normally required to work with the fluid transported within the line;
- depressurize the line and operate in this way:
  - positioning the valve in opened position and then empty the line;
  - handle the valve to put down the residue pressure contained inside the space between the ball and the body before of remove it from the line;
- during the disassembly apply the screw tool at the end of the valve nearest the pipe;

## MAINTENANCE

Verify the valve periodically, according to its application's field and its works' field and its work's conditions, in order to be sure that the valve works correctly.

## WARNINGS

- any deterioration or destruction of any part of the manually operated ball valve shall result in the need to replace complete valve: alterations to any part of the complete valve shall result in the valve no longer being in compliance with the performance requirements of EN 331 standard;
- ensure that the manually operated ball valve allows an adequate flow rate for its intended use;
- all installations should be performed in accordance with existing local installation regulations and codes of practice where they exist;
- it is imperative to follow the installation instructions of the manually operated ball valve manufacturer and of the appliance manufacturer, including those for the correct position of the connection point for the valve.

## MANUFACTURER

ITAP S.p.A.

via Ruca 19/21 - 25065

Lumezzane (BS), Italy

Телефон: +39 030 8927011

Факс: +39 030 8921990

email: [info@itap.it](mailto:info@itap.it)

web: [www.itap.it](http://www.itap.it)



# ПОЛНОПРОХОДНОЙ ШАРОВЫЕ КРАНЫ ДЛЯ ГАЗА: LONDON

## LOSS DIAGRAM (With water)

	1/4"	3/8"	1/2"	3/4"	1"	1"1/4"	1"1/2"	2"
KV	3,45	5,00	15,65	26,26	41,44	63,69	101	169

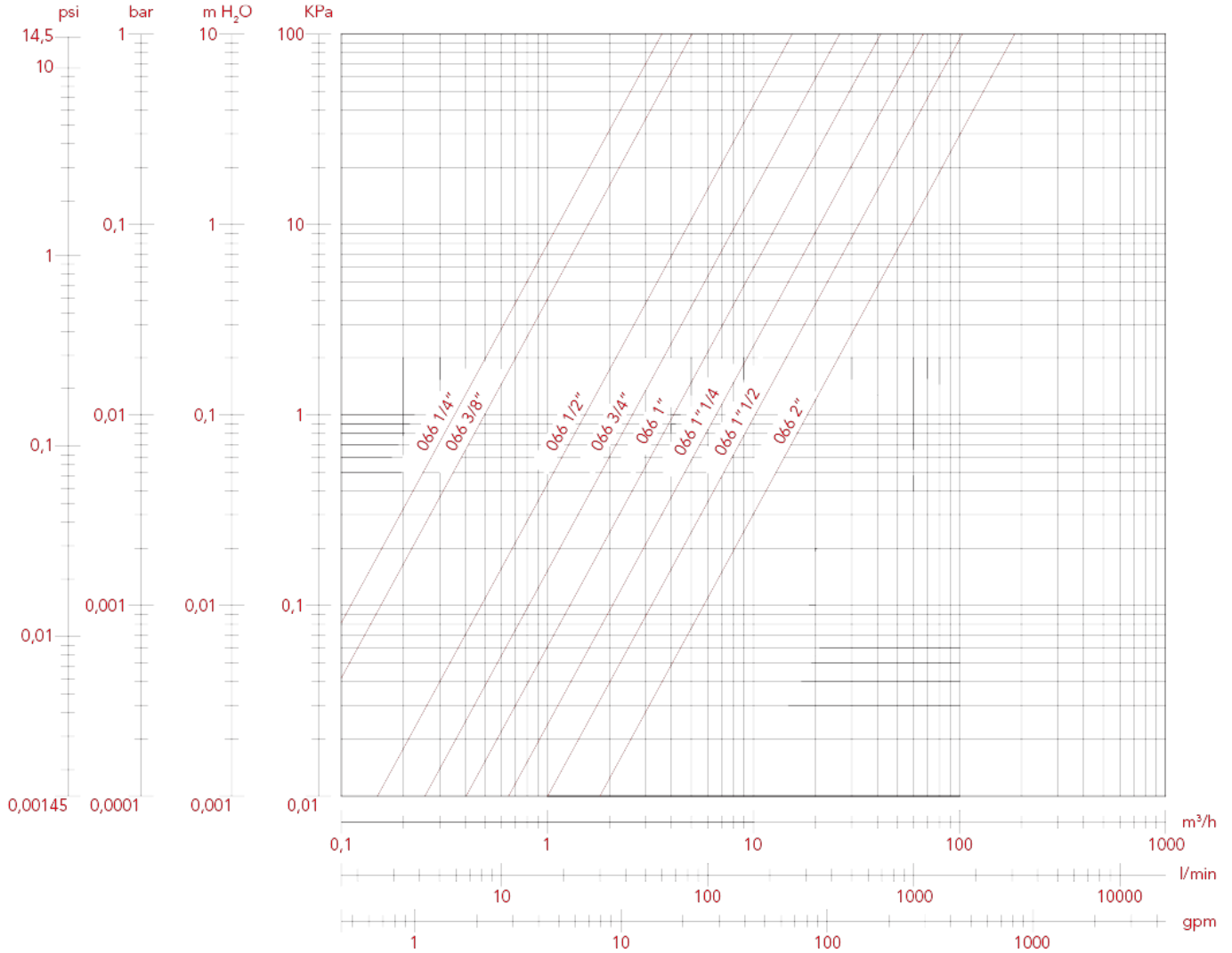



# ПОЛНОПРОХОДНОЙ ШАРОВЫЕ КРАНЫ ДЛЯ ГАЗА: LONDON

## PRESSURE-TEMPERATURE DIAGRAM

The values shown by the dropping lines state the maximum limit of employment of the valves.  
The shown values are approximate.

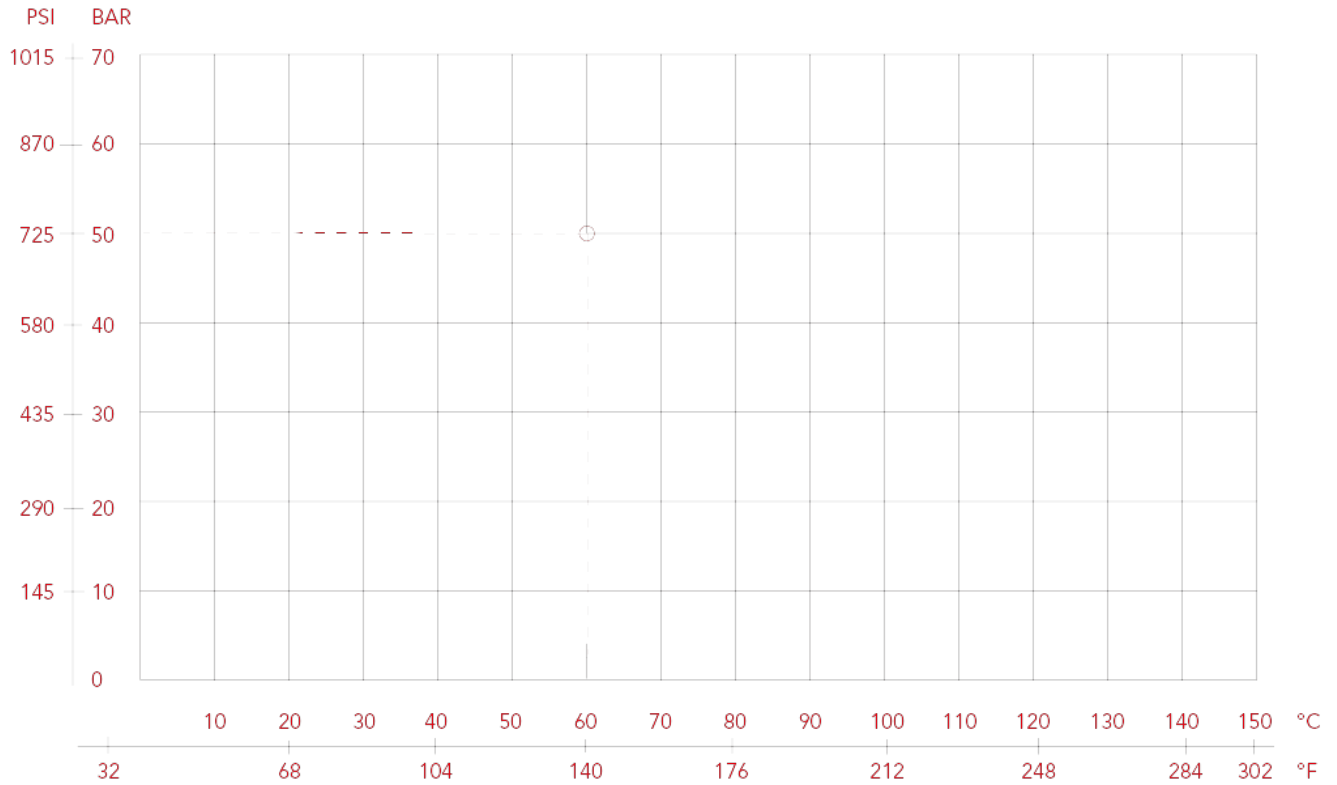





**ITAP S.p.A.**  
Via Ruca 19  
25065 Lumezzane  
Brescia (ITALY)  
Tel 030 8927011  
Fax 030 8921990  
[www.itap.it](http://www.itap.it) - [info@itap.it](mailto:info@itap.it)

We reserve the right to make improvements and changes to the products described herein and to the relative technical data, at any time and without forewarning.

rev. 20210330